



# Step by step to Finnish EMS2 rules and 900 million km EMS2 traffic

Otto Lahti, Finnish transport agency Traficom



# Agenda

- 10 Steps to Finnish EMS2 rules
- Current EMS traffic
- Electrifying EMS2 combinations



FORUM





# Sweden's trials inspire Finnish transport sector



FORUM

2010-2011



Light containers  
Helsinki-Tampere  
Helsinki-Lahti

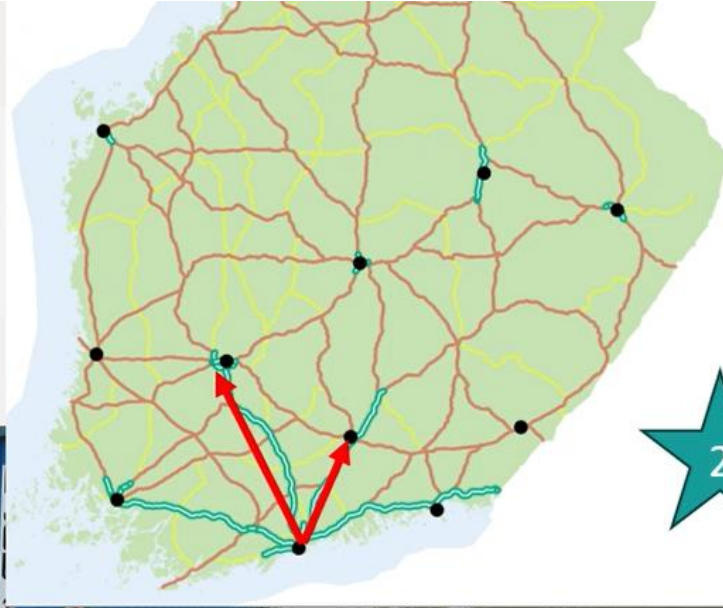

## The first trial in Finland

- In the fall of 2012, the Ministry of Transport published a strategy that mentioned the launch of HCT truck trials.



- The first application 2013 spring
- Traffick started 20.11.2013



- The initial reaction of transport organizations and citizens to the trial was generally negative.



FORUM





# Example of an perfect trial

## 3x different trailer sets and routes, 2x different trucks



FORUM



This is not a failure  
In trials you are searching the limits

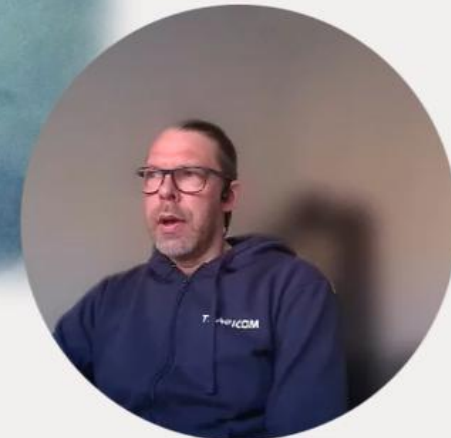

FORUM

Making the final proposal was easy when you could compare different options in theory and in traffic.

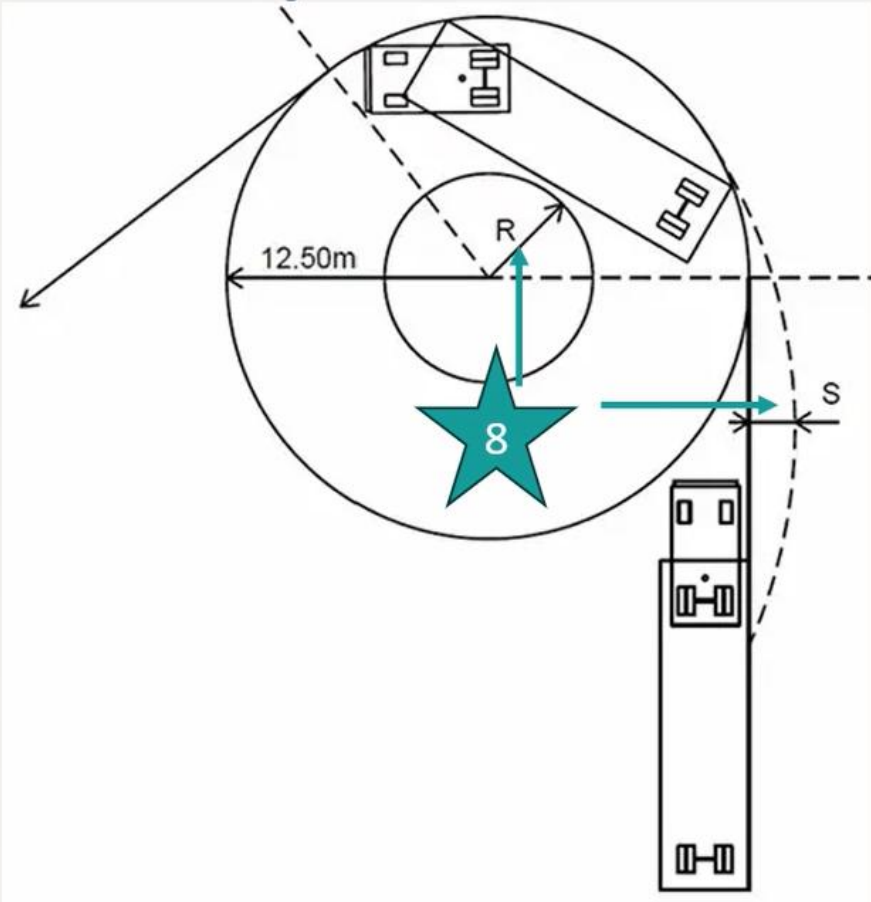

FORUM

# All new 32 m A-doubles should be as safe as average 25,25 m EMS



- HCT-calculator for stability and turning
- 2015 level safety equipment to all vehicles
- 9% on steering axle and 20% on driving axles + automatic chains in wintertime



Mirror view Cameras to avoid blind spots

- 9% on steering axle and 20% on driving axles + automatic chains in wintertime



FORUM



# Quick change to heavier combinations

- Base level 60 t 25 m
- 76 t since 10/2013
- 34,5 m since 2/2019
- 2024 74/76 combinations
  - 40 % of km
  - 50 % of tkm

Distribution of km performance of heavy combinations

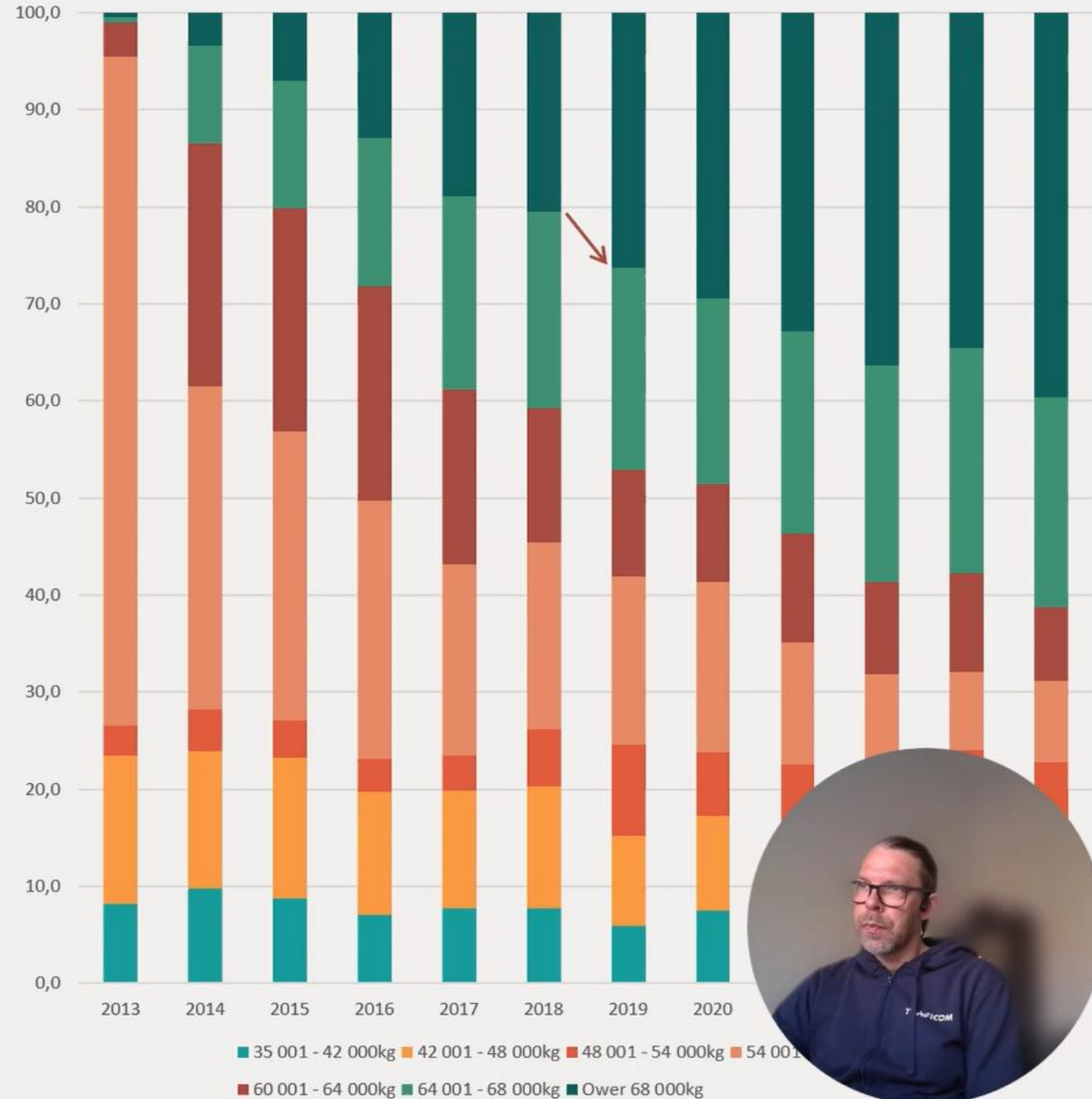

FORUM

# EMS2 traffic

Longer than 28 m

- 2019 transport volumes were high and economy was growing -> EMS2 had fast start
- All the time transport sector finds more solutions where they can benefit from EMS2
- EMS2 17,6 % from heavy combination km in 2025
- On weekdays, there are 500-600 EMS2 trucks on the busiest highway north of Helsinki
- The daily record for a single location is 702 EMS2 trucks at 18.12.2025 on the Helsinki ring road

Year	Million km
pilots	16
2019	60
2020	90
2021	112
2022	120
2023	136
2024	
2025	

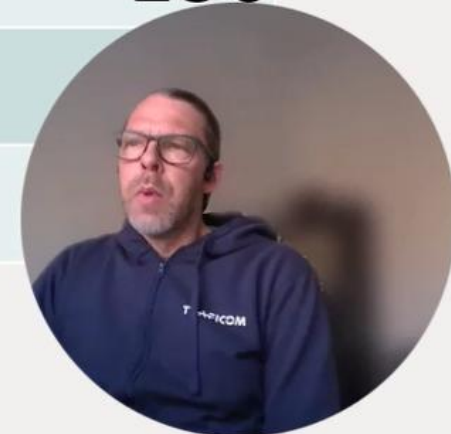

FORUM

# 20%

EU base level  
weight and dimensions  
Vs  
Current Finnish  
weight and dimensions  
in Finnish traffic

Calculated CO<sub>2</sub> reduction at 2021



FORUM



# EMS and EMS2 trucks have huge impact to truck traffic and emissions

- This calculation combines traffic volumes and the differences between weight classes
- Traffic volume would be 67 % higher with 16,5 m 40 t trucks
  - 778 750 000 km is lot of truck traffic
  - It would need 10 000 drivers
- Emissions would be over 20 % higher with out EMS and EMS2 trucks
  - Benefit from EMS2 is bigger with light goods

2021 traffic volumes

Mass	Traffic volume milj km	Savings milj km	CO2 %
35 001 - 42 000kg	81		
42 001 - 48 000kg	97	19,4	-10
48 001 - 54 000kg	83	20,75	-12
54 001 - 60 000kg	146	73	-15
60 001 - 64 000kg	130	91	
64 001 - 68 000kg	242	193,0	
Yli 68 000kg	381	3	
yht	1160	778,0	



# 25-30%

Expected CO<sub>2</sub> reduction by 2030

EU base level  
weight and dimensions  
Vs  
Current Finnish  
weight and dimensions  
in Finnish traffic



FORUM

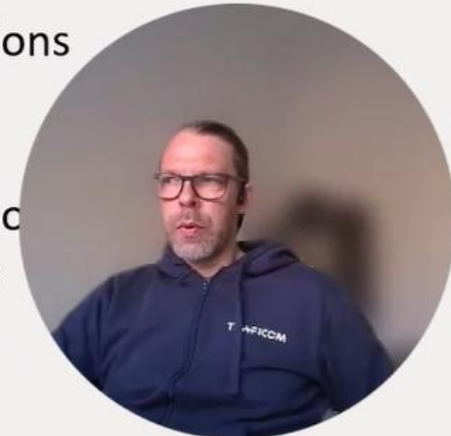



FORUM

# The first electric EMS2

- In traffic since 2023/10
- Operates Helsinki – Tampere
- 100 000 km annually
- GCW 68 t





FORUM

# eTrailer works as part of the A-double

- 6x2 500 hp tractor + 120 kw eAxle in trailer
- excellent performance and fuel economy
- The first pilot in traffic since 5/2023



Unloading to hardware store  
165 km north from arctic circle



Picture 16.1.2023 15:17

**Thank you for your  
interest**

**My contact information**

Otto.lahti@traficom.fi