

THE EQUALISATION OF TRUCK BOGIE AXLE WEIGHTS

by

I C P Simmons and C G B Mitchell

Vehicles and Environment Division

Transport and Road Research Laboratory

Crowthorne, Berkshire, England

1. INTRODUCTION

In Britain, as in many countries, there is a requirement for semi-trailers with more than 2 axles and rigid trucks with 3 or more axles to have "compensating systems" which ensure that under the most adverse conditions every wheel remains in contact with the ground and is not subject to abnormal variations of load. This forms part of the British Construction and Use Regulations (Department of Transport 1986). The Transport and Road Research Laboratory has been conducting a research programme on truck suspensions, which has included roadside measurements of truck axle weights in service, laboratory studies of how well compensating systems actually equalise semi-trailer axle loads when the trailer is tilted, and road measurements of how axle loads vary as an articulated goods vehicle traverses a hump bridge at low speeds. All these tests described are measuring static or quasi-static processes: that is, the forces in the suspension are the result of the vehicle weight and the geometry and stiffness of the suspension components. Inertia loads and dynamic forces are sufficiently small to be ignored. A simple mathematical model is being developed to improve the understanding of the experimental results and to identify the causes of the various effects observed. The dynamic effects of suspension systems are being studied and are reported elsewhere (Mitchell and Gyenes, 1989).

There are three commonly used types of bogie suspension found in Britain, shown in Figure 1. These are steel leaf springs connected by a balance beam to equalise loads, air springs interconnected to provide levelling and static equalisation, and a centrally-pivoted bogie system using either rubber or steel springs. The majority of semi-trailer suspensions found in Britain are currently based on steel leaf springs but the proportion of air sprung systems is growing rapidly. All three types of suspension are found on the rear bogies of rigid vehicles, but rubber is rarely fitted to semi-trailers.

Roadside surveys have been carried out to examine the variation of static axle loads within bogies. Results from the work done in 1985 at Stafford on the M6 (Mitchell, 1987) show that 3-axle steel sprung semi-trailers do not equalise at all well whilst similar air sprung bogies equalise considerably better. These results are demonstrated in Figure 2(a) which shows the highest and lowest axle loads within a bogie plotted against bogie load for both steel and air sprung systems. Measurements for 2 axle semi-trailer bogies (not shown here) show as much inequality of axle loads. A similar set of results for rigid goods vehicles is shown in Figure 2(b). Generally speaking the equalisation of these vehicles is much better than for semi-trailers. Tests of the sensitivity of enforcement axle weighers to unevenness of the ground in which they are set confirm the way in which axle loads for semi-trailer bogies change when one axle is raised relative to the others (Prudhoe, 1988).

2 LABORATORY TESTS OF AXLE LOAD EQUALISATION

2.1 SEMI-TRAILER TILT TESTS

A series of laboratory tests have been conducted to examine how the load transfer between multi-axle bogies varies with trailer bed slope. The trailer, laden with concrete blocks, was parked with the brakes off on a set of calibrated weighpads. The tractor was disconnected and the front of the trailer raised and lowered using a crane. The trailer bed angle was calculated from measurements of the front and rear trailer heights.

Results from early tests in 1983 by Crane Fruehauf showing the variation of trailer axle load plotted against kingpin height for both steel and air sprung semi-trailers are given in Figure 3. These clearly demonstrate that the steel sprung system did not equalise well whilst the air system equalised closely. Tests, also in 1983, by a major operator showed similar results for 2 and 3 axle semi-trailer bogies with steel springs. TRRL subsequently started laboratory tests to improve the equalisation of a monoleaf steel sprung bogie with a 2.02 metre wheelbase. A low friction liner was placed between the sliding faces at the spring ends; this material had a coefficient of friction of the order of 0.08 compared with 0.4 for steel. Figure 4 shows the relationship between axle load and trailer bed angle for a standard steel sprung semi-trailer and the same vehicle fitted with the low friction liner. The results clearly show reducing the friction in the spring ends improved the equalisation between the axles on the semi-trailer tested. An equaliser pivot bush with low friction and low torsional stiffness was also tested but this produced no significant improvement in equalisation.

More recent tests with a major component manufacturer have confirmed these results and have indicated that the friction in the outer ends of the springs is the dominant factor on a long wheelbase 2 axle bogie for a semi-trailer.

2.2 TESTS WITH AN INSTRUMENTED SEMI-TRAILER BOGIE

Further work has been carried out using a different multileaf steel sprung 2 axle semi-trailer with an axle spacing of 1.45 metres. The bogie suspension has been instrumented to measure the longitudinal forces in each half of the two springs on one side of the vehicle. In addition the longitudinal forces in the radius rods, the vertical deflections of the springs and the longitudinal movement of the trailing spring were measured.

These tests with the short wheelbase bogie gave similar poor equalisation when the trailer bed was tilted as was found for the long wheelbase bogie. Figure 5 shows the individual forces in each part of the bogie suspension. Longitudinal forces developed in each half of the springs and the radius rods.

When the trailer was tilted nose down, the load in the front wheel increased and the load in the rear wheel decreased as found with previous tests with similar semi-trailers. At the same time the longitudinal loads in the two halves of the rear spring became tensile and the load in the rear radius rod compressive. The front and rear halves of the front spring went into compression by similar amounts whilst the load in the front radius rod remained in tension.

As the trailer was tilted nose up, the load on the front wheel decreased whilst the load on the rear wheel increased. The loads in the front and rear halves of the rear spring were both compressive but the front half of the spring appeared to be subjected to a load about three times that on the rear half. Meanwhile the rear radius rod went into tension by an amount equal and opposite to the compressive load in the front half of the rear spring. At the same time a tension load developed in the front and rear halves of the front spring ; the front radius rod also went into tension.

The physical position of the radius rods was near horizontal at the mid-point of the tests and only a small longitudinal movement of the rear spring ends was seen : the earlier tests with the longer wheelbase trailer, which had more steeply angled radius

rods, produced a movement of the rear spring ends of about 20 mm. This could explain why, on the trailer with the short wheelbase bogie, reducing the friction at the spring ends had little effect on axle load equalisation. As before, reducing the friction and torsional stiffness of the pivot bush had no significant effect on the equalisation between the axles. The equalisation tests on the short wheelbase bogie showed that the geometry of the suspension, as well as the friction at the spring slipper ends, affects the equalisation performance of the bogie.

2.3 TILT TESTS ON A FODEN 3 AXLE TRACTOR

A different version of equalising mechanism for a bogie using multileaf steel springs and a central pivotted equaliser beam was available on the rear pair of axles of a 3 axle tractor unit at the TRRL. The springs had pin joints at the front of the leading spring and rear of the trailing spring with each spring coupled to the equaliser by a shackle as shown in Figure 6(a) .

The tractor unit was tilted in a similar way to the trailer tests and the variation of wheel load measured against chassis angle. The results are shown in Figure 6(b). The equalisation of axle loads within the bogie was much better than for the semi-trailers. This is almost certainly due to the change in geometry and reduction in the friction at the spring ends, as well as possibly due to the lack of separate radius rods.

Although this type of system is acceptable for a tractor unit it may not be satisfactory for a semi-trailer as there will be a tendency for the rear axle to lift under braking. However, it does demonstrate that a steel sprung bogie can be made to equalise reasonably well.

3 TESTS ON HUMP BRIDGES

The factors that cause unequal axle loads when semi-trailers are tilted also cause the axle loads to change when the vehicle passes over a hump bridge or some other road hump. Articulated goods vehicles have been instrumented to examine the dynamic pavement loads transmitted through the tyre patch. These were used to study the variation of axle loads as the vehicle crossed one of a number of hump bridges on public roads. Strain gauges were used to measure bending of the axle between the spring and wheel. Inertia loads from the outboard mass were measured with a potentiometric accelerometer. From these two measurements the total axle load can be calculated. The transducer signals were passed through electronic circuits to provide amplification and balance before being recorded on analogue magnetic tape. Each transducer was calibrated prior to the test and the instrumentation includes a fixed percentage change calibration for use at runtime to check the gain of the electronics in the data recording system. The recorded data was replayed into a digitising system and passed to a Hewlett Packard desktop computer system for detailed analysis.

Semi-trailers fitted with both steel and air sprung 2 and 3 axle bogies have been tested over several different hump profiles. These include typical arch bridges found on minor roads in Britain, a bridge on a rural dual carriageway and a specially constructed hump on the TRRL test track. Each test vehicle was loaded with concrete blocks to as near the legal axle load limit as possible, tyre pressures were set to the manufacturer's recommended values and the ambient conditions recorded. The vehicle was then driven over a series of hump bridges at speeds ranging from 16 to 40 km/h. On one bridge,

on a rural dual carriageway, it was possible to cross the bridge at 72 km/h. The heights of the crests of the hump bridges varied from 0.3 to 2.3 m above the approach roads. A hump on the TRRL test track had a crest 6 m above the approach road.

Results for one typical bridge are given in Figure 7 showing wheel load histories for steel and air sprung 3 axle semi-trailers. These show clearly how in both cases the front axle loads up, the rear axle unloads by a similar amount, and the middle axle acts as a pivot. The steel sprung front axle reaches a peak load of 13.5 tonnes (7.4 tonnes static axle load) on the crest of the hump whilst the air sprung front axle has a maximum load of 8.9 tonnes at the same point. Similar results have been found for 2 axle semi-trailers, for which the front axle load increased and the rear axle unloaded at the crest of the hump. These results demonstrate how the better static equalisation of an air suspension bogie is reflected in the low speed equalisation when running over a hump.

A summary of the results of tests with 3 axle steel and air sprung bogies is given in Figure 8. The profile of each hump is shown together with the peak front axle loads on the crest at the particular speed tested. In all cases the steel sprung bogie showed large increases in the front axle load with peak loads of between 10.9 and 13.5 tonnes. The air sprung bogie equalised much better exhibiting peak loads of between 8.3 and 9.4 tonnes on the front axle. Bridge designers make use of the peak load factor, (the peak value of the load divided by the static load). This indicator can also be used to compare the performance of the two systems. For the data above, peak load factors varied between 1.47 and 1.82 for the steel sprung front axle and between 1.16 and 1.31 for the air sprung front axle, for static loads of 7.4 and 7.2 tonnes on steel and air respectively.

Both sets of results for the steel and air systems demonstrated that the peak axle loads appeared to be rather insensitive to the height of the hump and not to vary much with speed. Tests on one bridge on a dual carriageway at 72 km/h showed similar results to tests at lower speeds, though at that speed the dynamic bouncing normally encountered can add to the quasi-static peak loading. The peak load on the hump bridges related best to the radius of the crest of the bridge, but for two bridges this was not a good predictor.

4 CONCLUSIONS

Both roadside surveys and full-scale laboratory tests have shown that air sprung multi-axle semi-trailer bogies equalise much better than the majority of steel sprung bogies.

Tests have indicated that the geometry of steel sprung systems is important to achieve equalisation. In some cases reducing the friction of the sliding spring ends improved equalisation considerably.

An instrumented bogie has allowed the loads in the two halves of each spring and the radius rods to be measured. Axial loads in the springs and radius rods of a bogie with half axle loads of about 4 tonnes were 0.5 - 1 tonne.

Tests of a tractor unit fitted with a 2 axle bogie have shown that good equalisation can be achieved with steel sprung systems. Systems with pivoted springs seem to perform better than systems which require steel springs to slide over steel

contact faces and do not require radius rods to locate the springs to the chassis. However, bogies of this type do experience large changes in axle loads during braking.

Instrumented vehicles have been run over a series of hump bridges on public roads to examine the variation in the axle loads of semi-trailer bogies on such bridges. Lack of equalisation in the steel sprung bogie of a 3 axle semi-trailer generated peak load factors between 1.47 and 1.82 times the static axle load. The air sprung bogie equalised much better and produced peak load factors between 1.16 and 1.31. In both cases the front axle increased in load whilst the rear axle unloaded. Two axle semi-trailer bogies behaved in much the same way. The peak loads occurred when the front axle was on the crest of the hump.

The peak loads generated by both the steel and air sprung bogies appeared rather insensitive to either the height of the hump or the speed at which it was taken. Results from tests carried out at 72 km/h were similar to those from tests at lower speeds.

5 ACKNOWLEDGEMENTS

The work reported in this paper forms part of the programme of the Transport and Road Research Laboratory, and the paper is published by permission of the Director. Crown Copyright. Any views expressed are not necessarily those of the Department of Transport. Extracts may be reproduced, except for commercial purposes, provided the source is acknowledged. The authors would like to acknowledge the assistance to the work reported here given by T.Williams, D.J.Jacklin and K.T.Rooney. The authors also wish to thank Crane Fruehauf for permission to publish the test results shown in Figure 3.

6 REFERENCES

Department of Transport (1978). The Motor Vehicles (Construction and Use) Regulations 1978. Department of Transport, Statutory Instrument 1978 No 1017. H M Stationery Office, London.

Mitchell C G B (1987). The Effect of the Design of Goods Vehicle Suspensions on Loads on Roads and Bridges. TRRL Research Report RR 115. Transport and Road Research Laboratory, Crowthorne.

Mitchell C G B and Gyenes L (1989). Dynamic Pavement Loads Measured for a Variety of Truck Suspensions. Paper to the Second International Symposium on Heavy Vehicle Weights and Dimensions, Kelowna, British Columbia, June 18-22, 1989. Roads and Transportation Association of Canada, Ottawa.

Prudhoe J (1988). "Slow Speed Dynamic" Axle Weighers: Effects of Surface Irregularities. TRRL Research Report RR 134. Transport and Road Research Laboratory, Crowthorne.

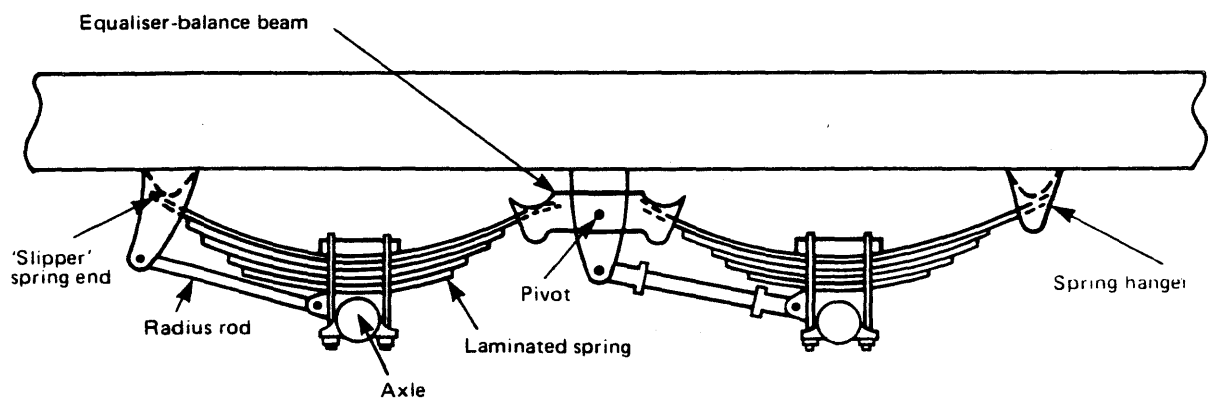

(a) Steel leaf spring

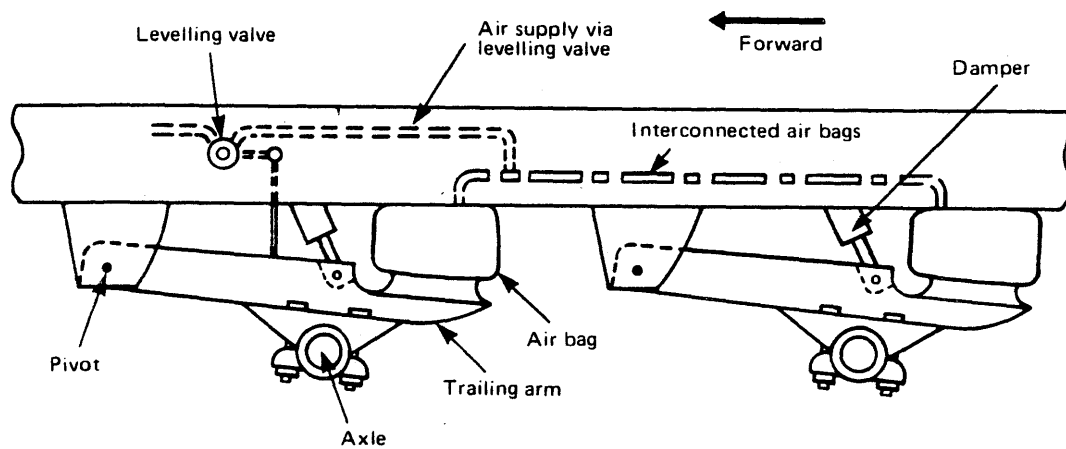

(b) Air spring

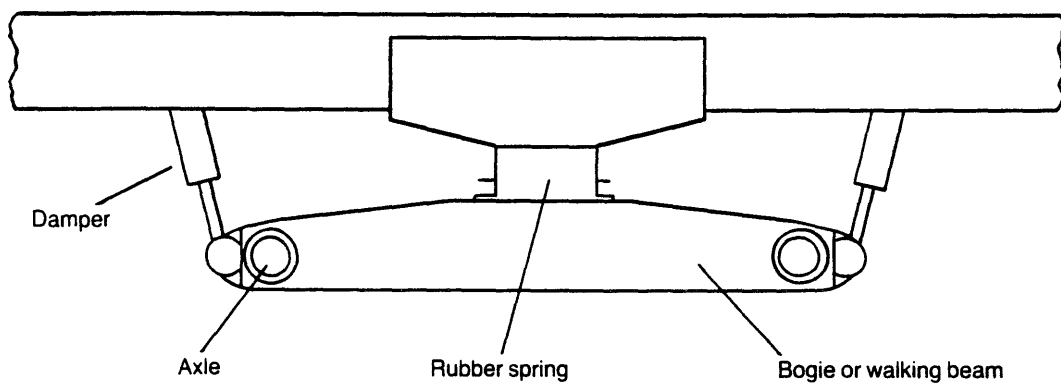

(c) Walking beam (many design variants)

Fig. 1 Three types of goods vehicle bogie suspension

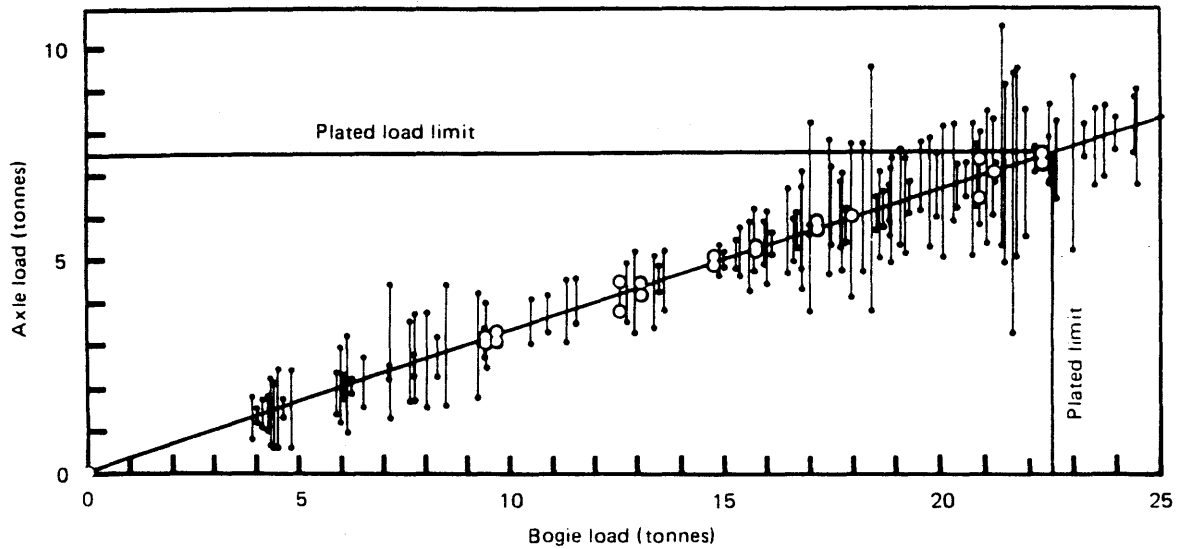

(a) 145 3-axle semi-trailer bogies

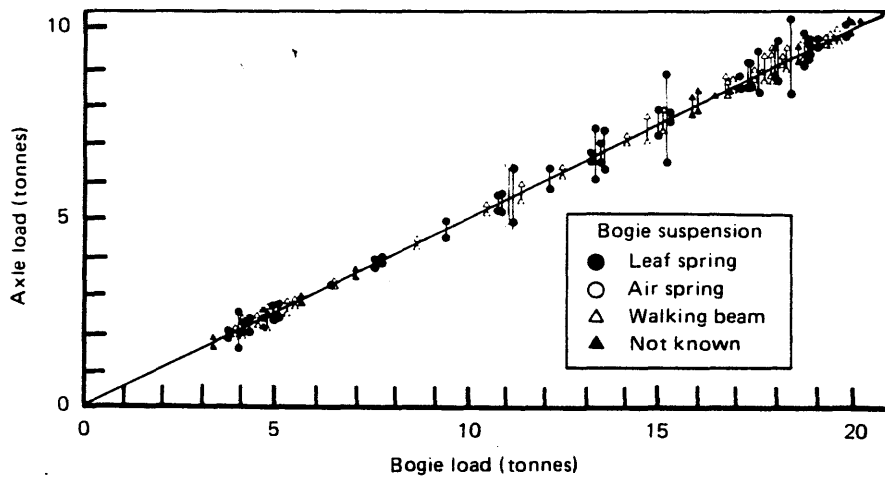

(b) 114 2-axle rear bogies on rigid vehicles

Fig. 2 Axle and bogie loads measured in a roadside survey on the M6 at Stafford, 1985
(Each vertical line represents the axle loads for one bogie)

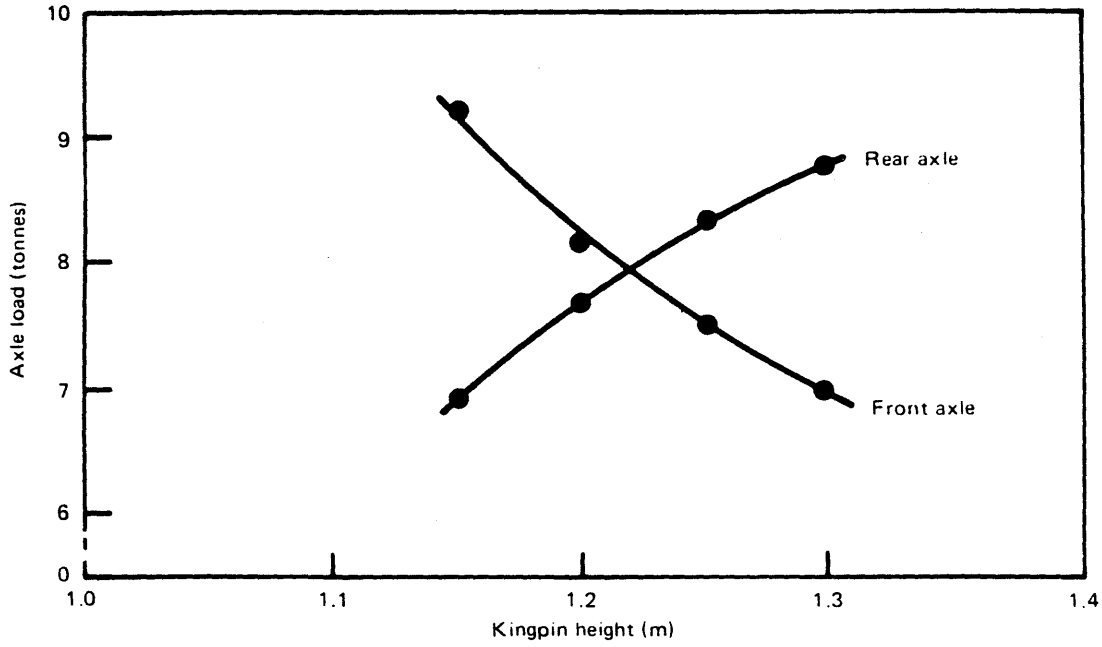

(a) Monoleaf steel spring suspension

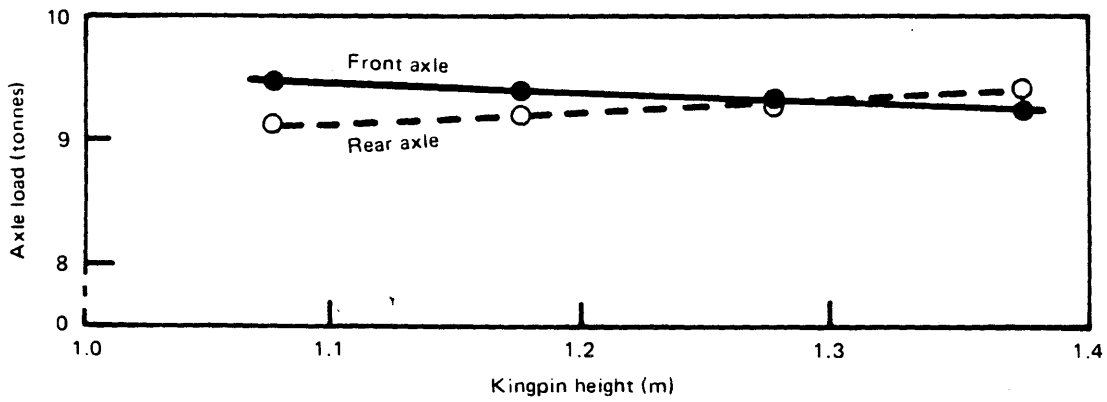

(b) Air suspension

Fig. 3 Loads on the front and rear axles of a 2-axle semi-trailer as the trailer attitude is changed
(Source: Crane Fruehauf unpublished tests)

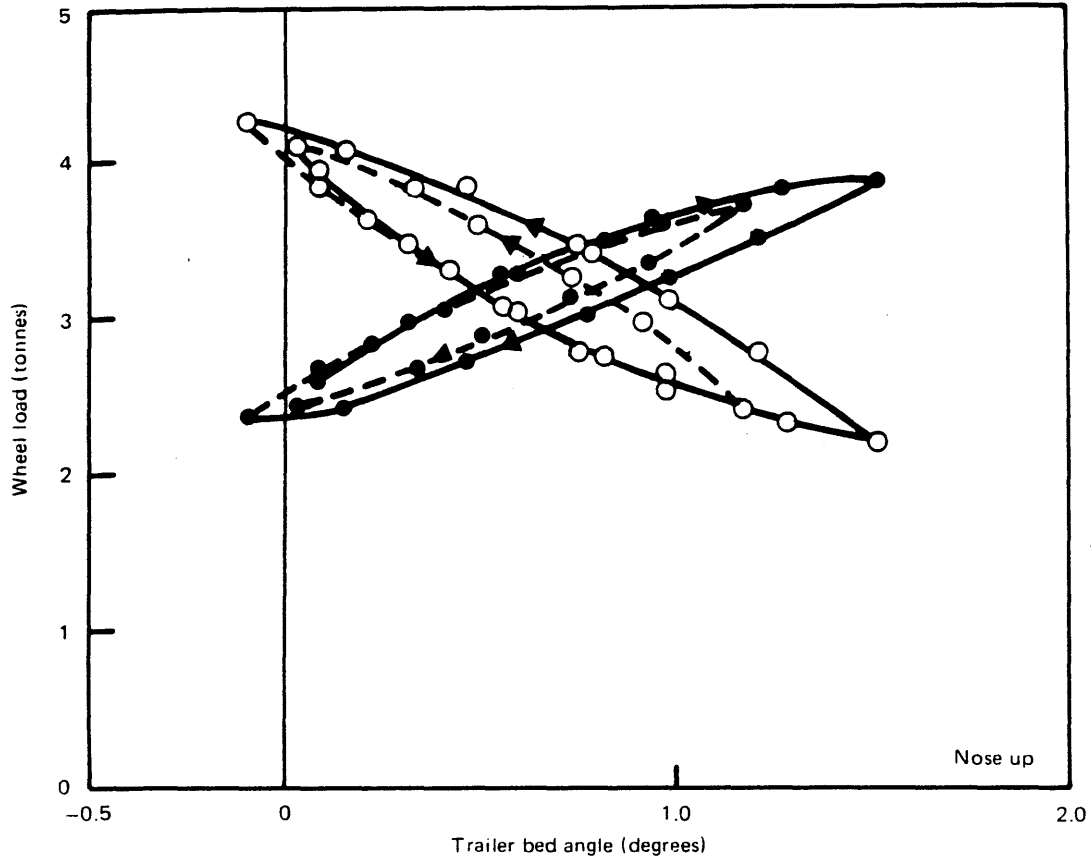

(a) Standard spring ends

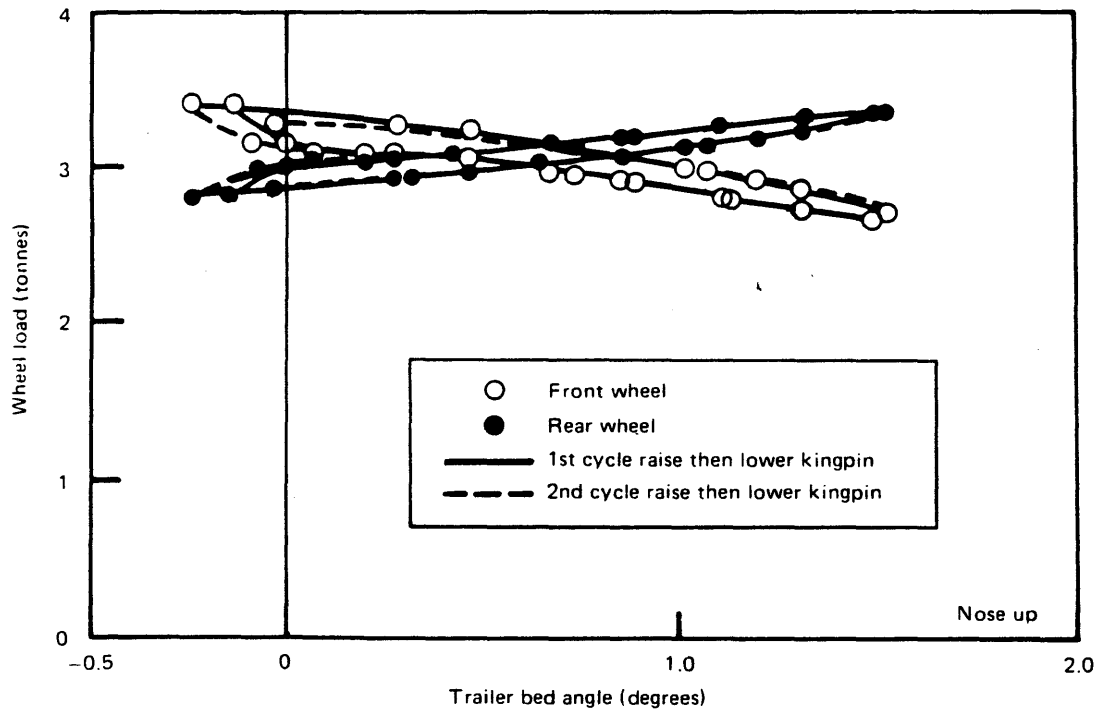

(b) Spring ends on PTFE (Teflon) slides

Fig. 4 Wheel load inequality on a 2-axle semi-trailer bogie with steel mono-leaf springs

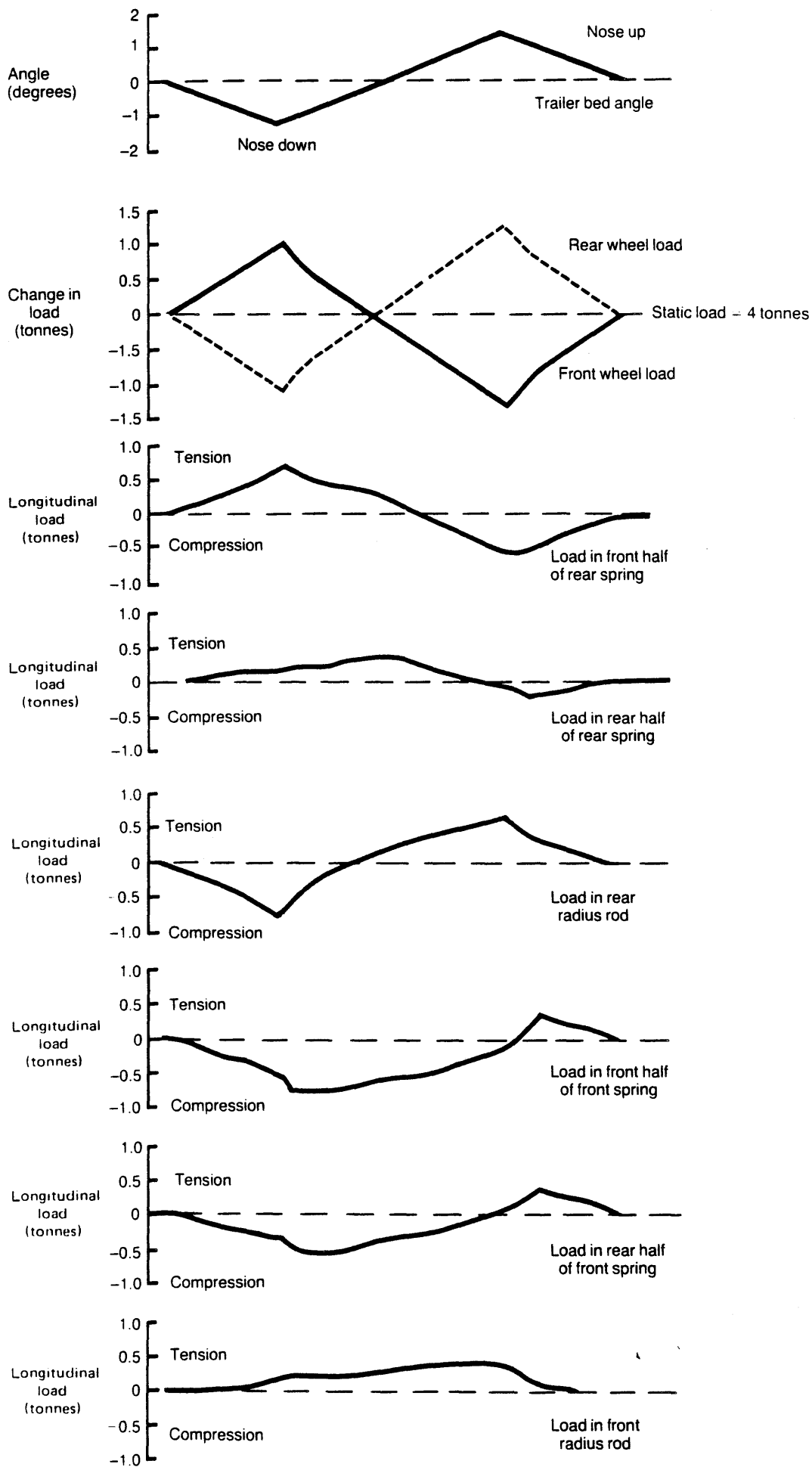
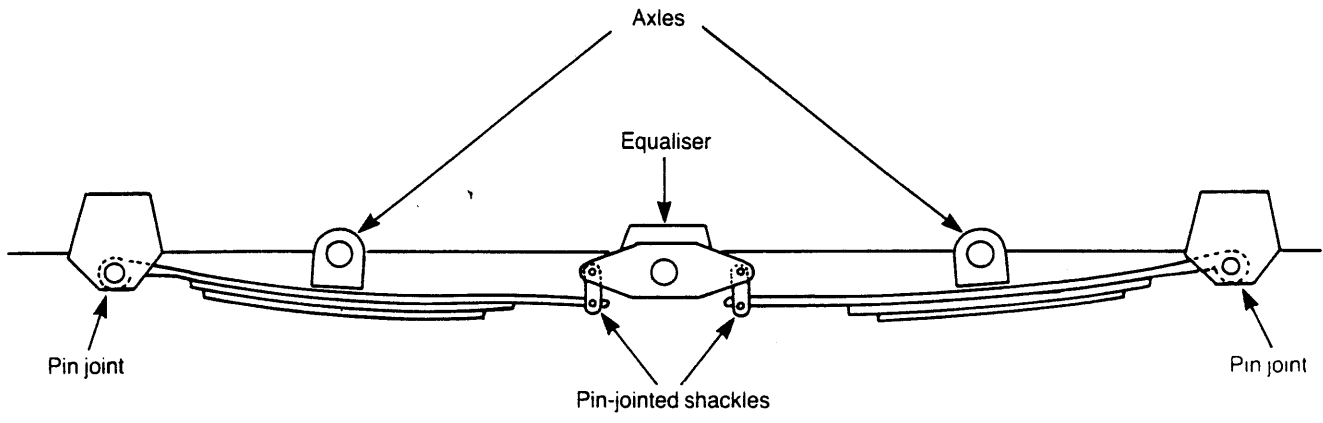
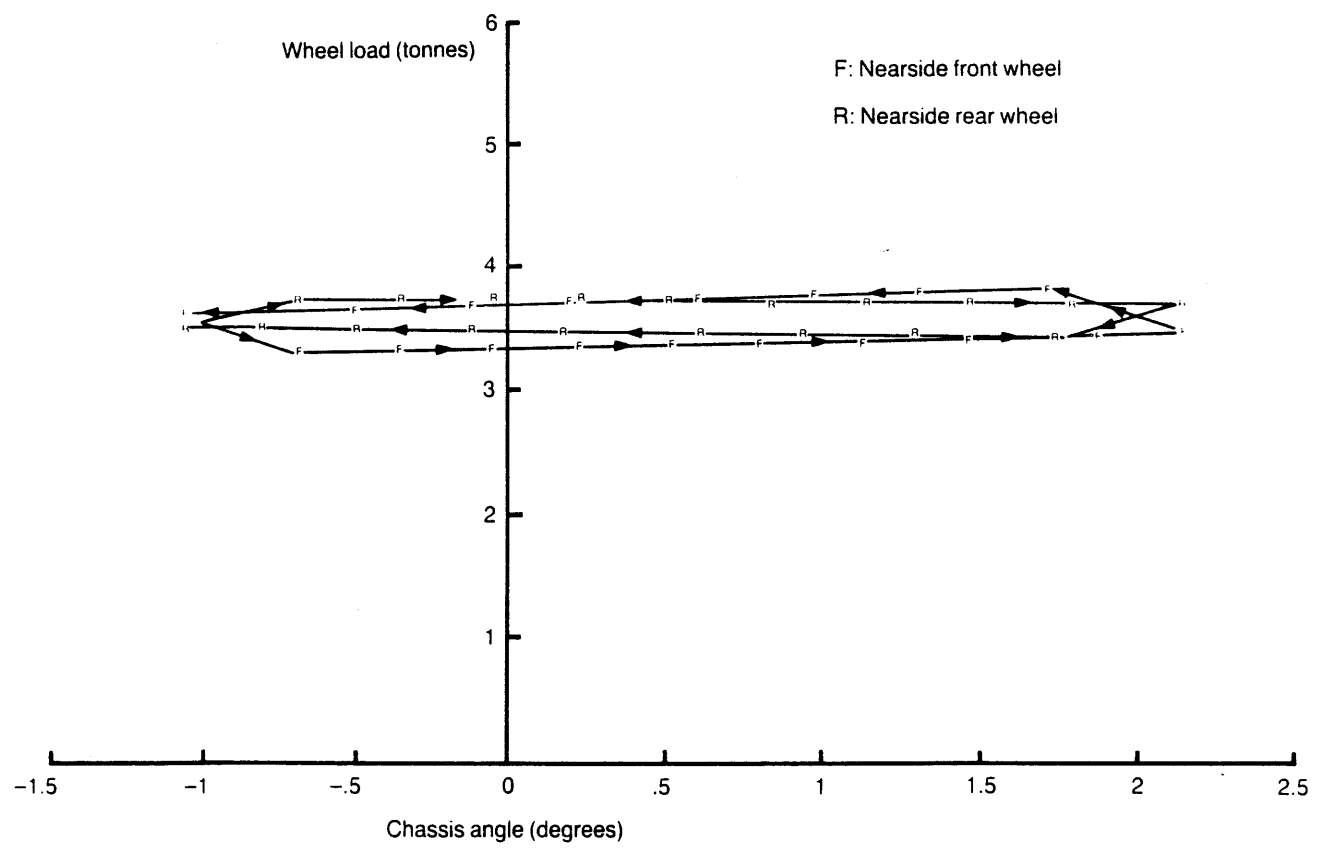

Fig. 5 Component loads in a 2-axle bogie when tilted



(a) Bogie layout for a Foden tractor unit



(b) Variation of axle loads

Fig. 6 Static load equalisation of a 2-axle bogie fitted to a Foden tractor unit

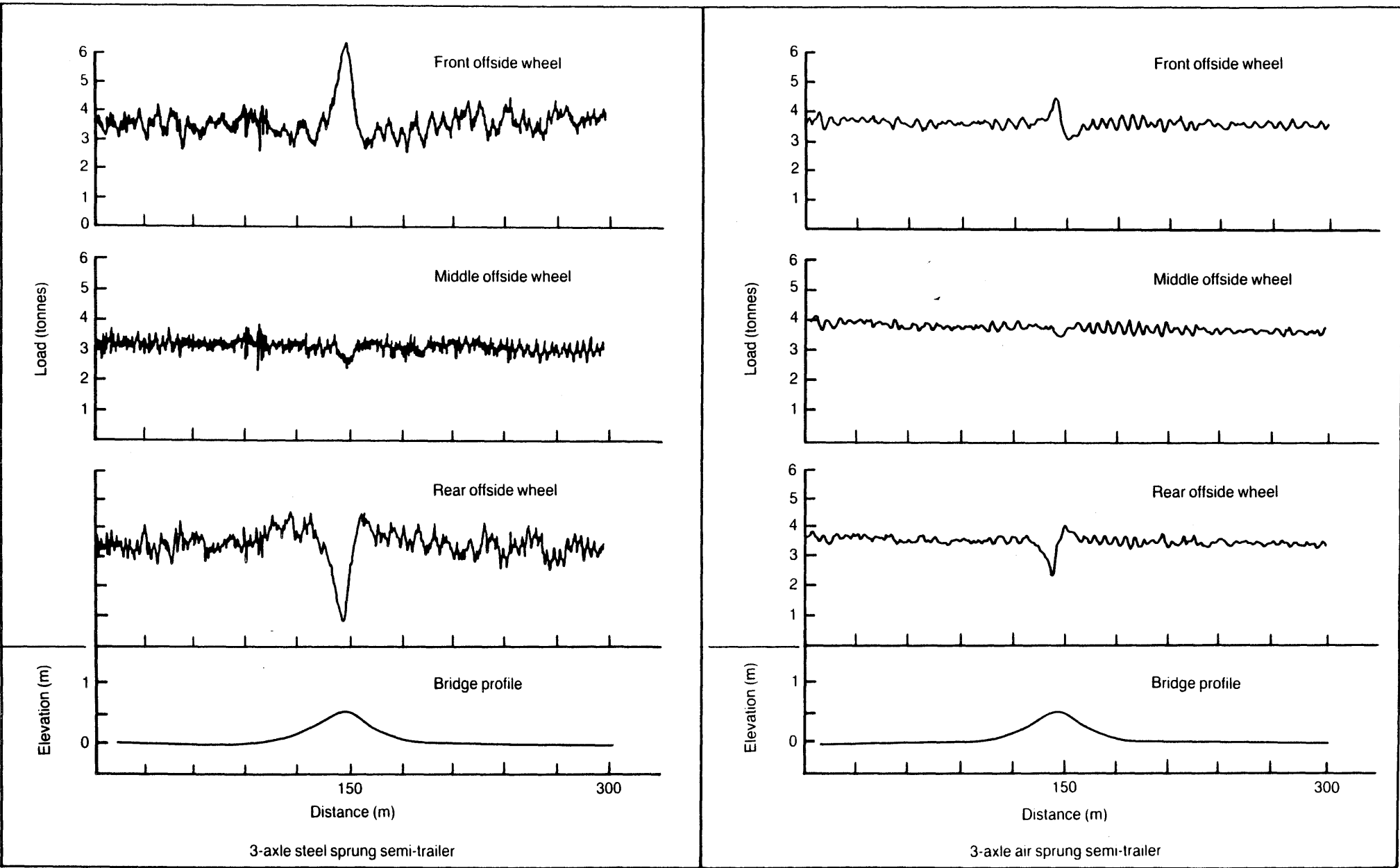

Fig. 7 Wheel load histories for 3-axle steel and air sprung semi-trailers running over an arch bridge at 40 km/h – laden

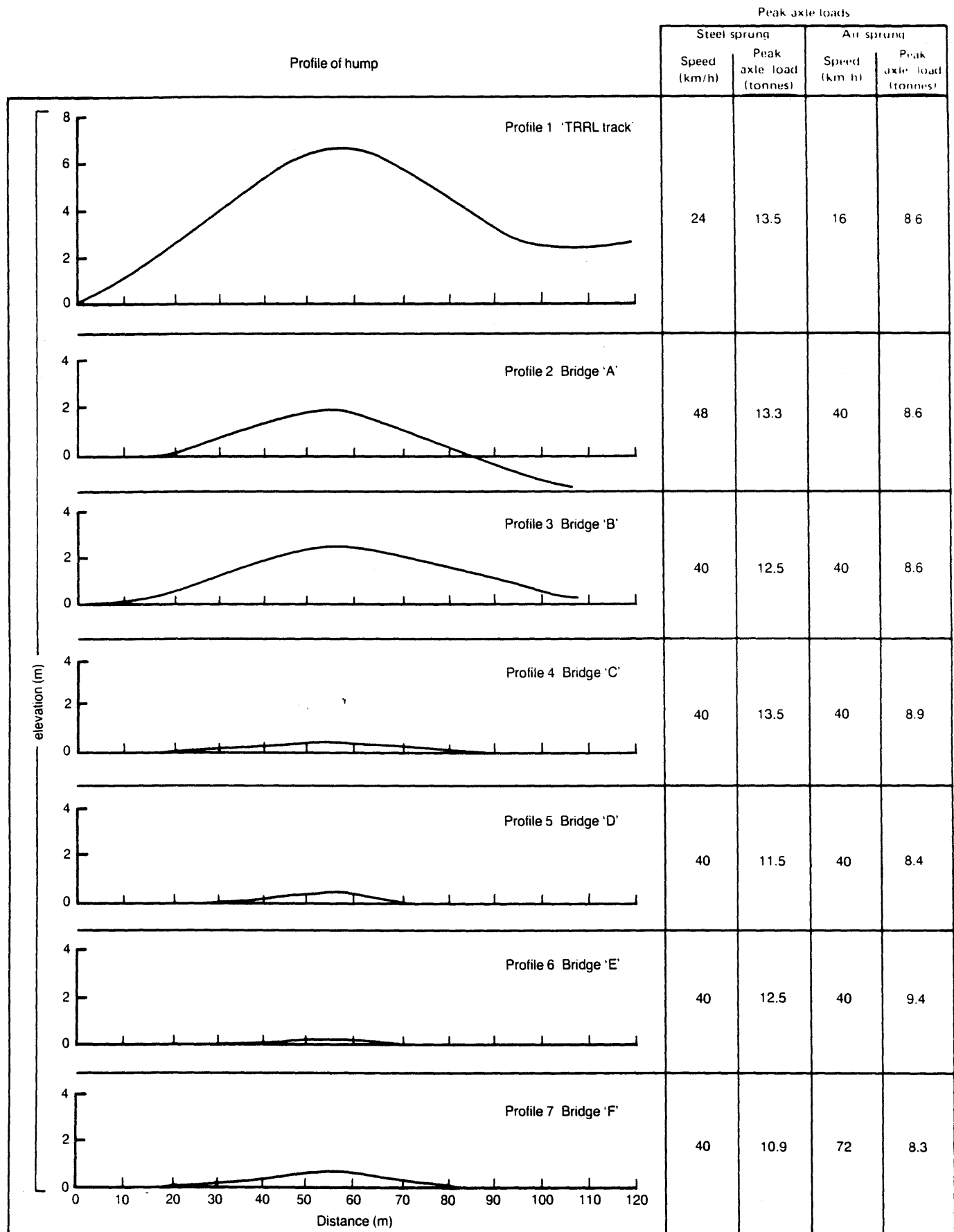

Fig. 8 Peak axle loads for the front axle of a 3-axle semi-trailer bogie running over different hump profiles

