

# Improvement of dynamic wheel loads and ride quality of heavy agricultural tractors by suspending front axles

G. RILL, D. SALG and E. WILKS, Regensburg, Germany

The development of agricultural tractors clearly shows the tendency towards faster vehicles. Heavy agricultural tractors driving on uneven roads at 40 or 50 km/h do not offer any ride comfort at all. High wheel load variations generate stresses and strains in roads and reduce ride safety to critical values. By means of a newly developed suspended front axle it is possible to considerably improve ride safety and ride comfort. The proven standard design of tractors is maintained. Field tests and computer calculations prove the effectiveness of a suspended front axle.

## INTRODUCTION

1. Today the farm tractors are all working machines mostly destined for agricultural use. Business developments, however, show an increasing tendency to multi-purpose vehicles. Besides the usual agricultural service, transport work is also carried out to an increasing extent. This way of using tractors gains in importance. The vehicle speed has an increasing influence on the economy of a tractor.

2. Vehicle speeds of 30 km/h are usual to date, but, vehicle speeds of 40 km/h are prevailing in those countries where permissible by law. Today some vehicles are even offered with permissible maximum speeds of 50 km/h or 70 km/h resp., Fig. 1.

3. The permissible maximum speed is first of all limited by the ride comfort and the ride safety. The ride comfort is mostly increased by suspended driver seats and in some cases suspended driver cabs are used.

4. Ride comfort and ride safety can be improved by actively influencing the three-point hydraulics. Of course, this is only possible if a heavy-duty mounted implement, e.g. a plough is attached.

5. Currently the non-suspended design causes high wheel load variations at the tractors. Due to this there are high stresses and strains in the road and the ride safety is severely affected.

6. With a suspended axle, as currently in development by ZF Passau, the ride comfort and ride safety of a tractor with or without mounted implements are clearly improved. For a perfect adjustment of the suspension, field tests are made together with computer calculations.

## STANDARD TRACTOR

### Concept

1. Today most tractors are made acc. to the so-called modular design. Rear axle, transmission and engine are rigidly connected to each other. For equalizing extreme ground unevennesses the front axle is movable round an axis in longitudinal direction of the vehicle.

2. The suspension of the tractor and the damping of the vehicle vibrations is exclusively made by large volume tyres. Different tyre sizes on front and rear axles as well as the driver's cab located in the rear third of the vehicle are the essential features of these vehicles, Fig. 2.

3. Various mounted implements can be located both in the rear and front area. Hydraulic lifting devices ensure an exact positioning of the implements. By means of P.T.O. shafts driving is also possible on these two main mounting areas. In practical service this results in a variety of loading alternatives, Fig. 3.



Fig. 1. JCB FISTRAC

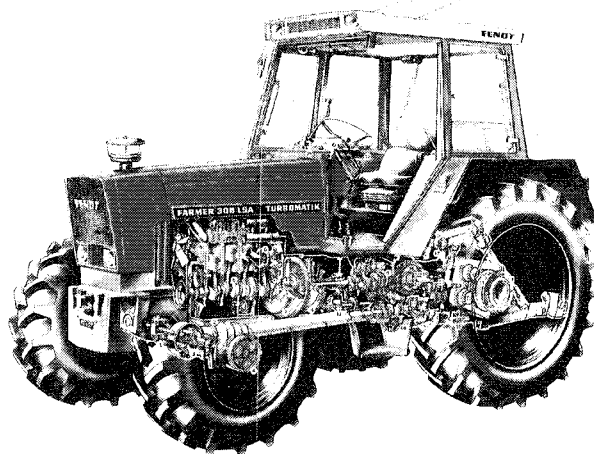

Fig. 2 Standard tractor

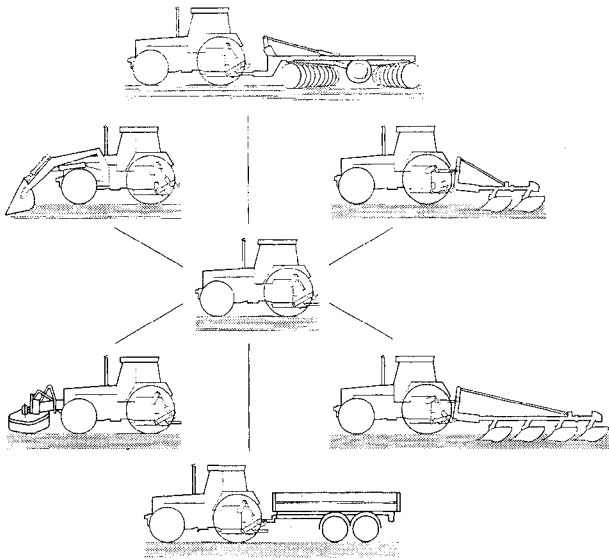

Fig. 3. Some loading alternatives

4. With an empty tractor the axle loads are rather evenly distributed on front and rear axle. In the case of heavy mounted front or rear units the relating axle is loaded up to 80% of the total weight,[1]. The Consequences of these extremely axle loads are considerably reduced ride safety, a lower ride comfort and high loads on roadways.

Dynamic Wheel Loads and Ride Quality

5. Fig. 4 shows the driving behaviour of a standard tractor on an uneven roadway (country road) at a speed of 50 km/h. The road profile is shown in Fig. 6. The front and rear-mounted implements result in a static load of 47 kN at the front axle and of 44 kN at the rear axle.

6. Considerably reduced ride safety and enormous load on the roadway are the consequences of these high wheel load variations. Furthermore the high shock load values in the vehicle body are unhealthy to the driver.

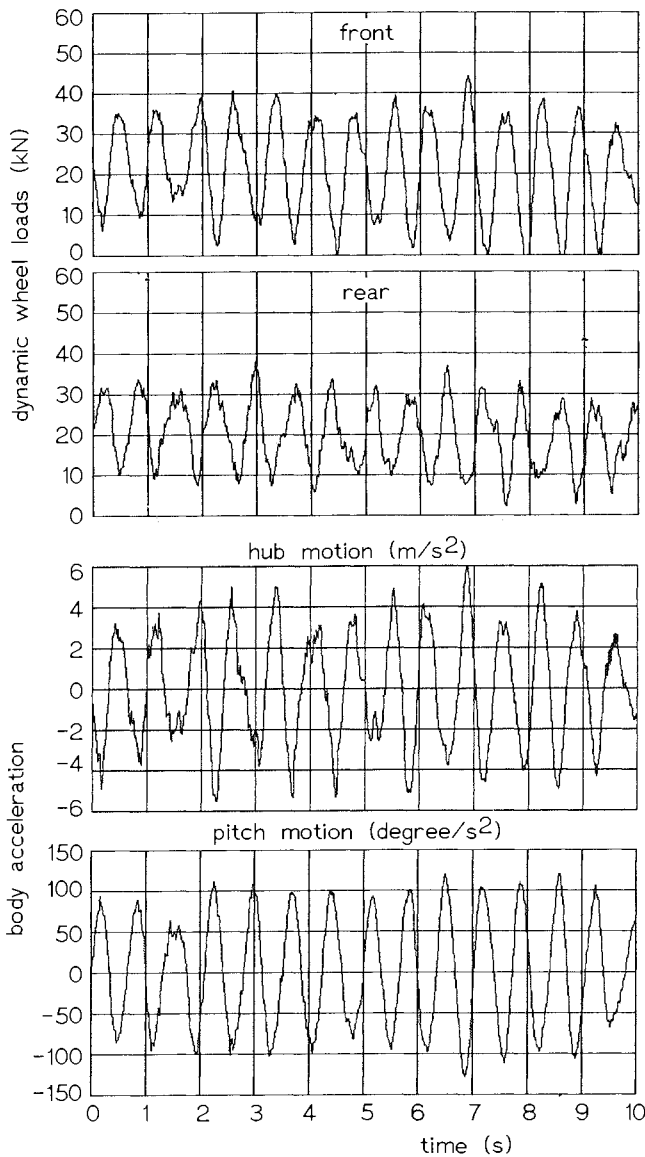

Fig. 4. Ride characteristics of standard tractor at high speed (50 km/h)

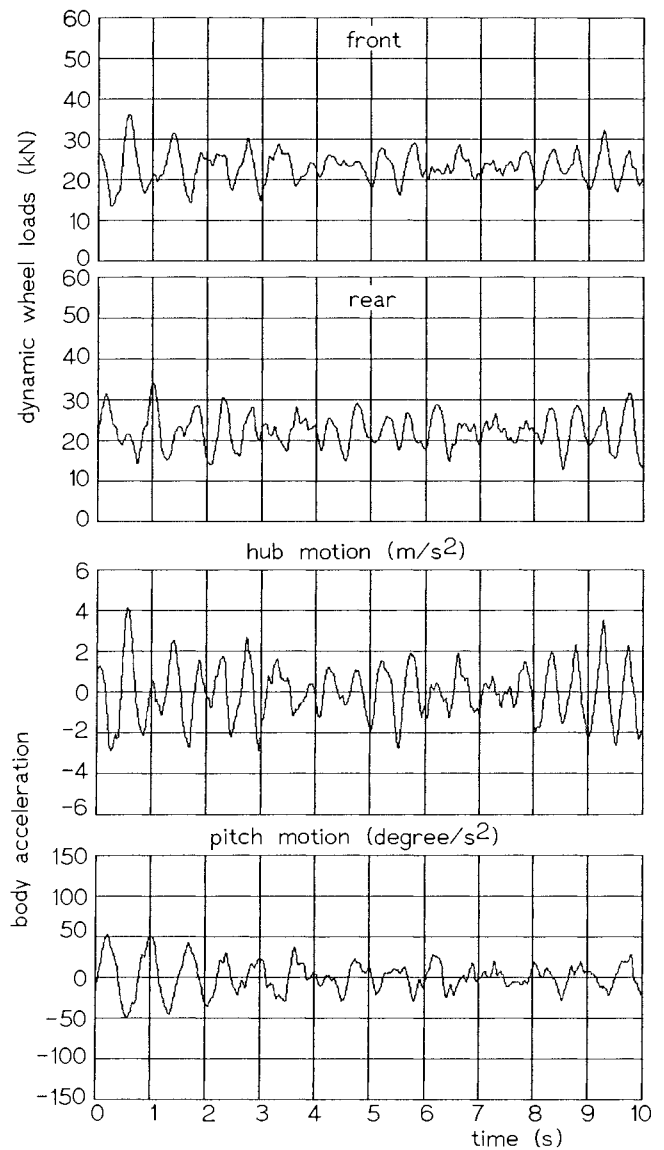

Fig. 5. Ride characteristics of standard tractor at low speed (20 km/h)

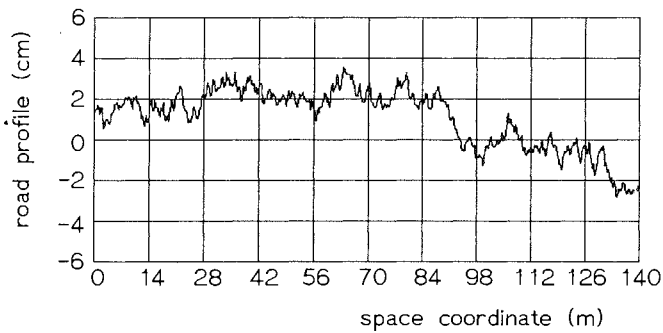

Fig. 6. Road profile

7. A vehicle speed decrease, e.g. to 20 km/h, obviously reduces the wheel load variations and improve the ride comfort, Fig. 5.

8. Longer transport times due to lower driving speeds, however, will reduce the economy of a tractor. Due to the installation of suspended front axles more ride safety and ride comfort can be obtained.

TRACTOR WITH SUSPENDED FRONT AXLE

State of the art

1. The characteristics required for a suspension system in the tractor are based on other objectives than for passenger cars or for commercial vehicles. The variety of possible combinations of mounted implements results in a large range of static axle loads in service. Furthermore rigidity as well as no influence at all on the control hydraulics of the mounted implements are the main demands.

2. Due to the modular design there are very few possibilities to suspend the rear axle. The tractor manufacturers have realized in time the necessity to use at least a suspended front axle. MAN and Fendt e.g. already offered corresponding vehicles in 1950, Fig. 7. In this case the front axle was connected with the body by means of a leaf spring, as done by other manufacturers. However, this concept could not penetrate the market, [5].

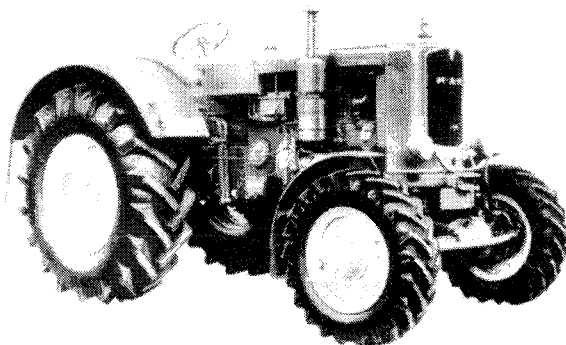

Fig. 7. MAN tractor with suspended front axle



Fig. 8. MB-Trac

3. Only in 1972 a vehicle with front axle suspension was produced in the Federal Republic of Germany, i.e. the MB-Trac, Fig. 8. Also in this case a mechanical suspension is obtained by two coil springs.

4. A new vehicle in Trac-design is the JCB-FASTRAC, Fig. 1. Depending upon the version this vehicle reaches driving speeds up to 80 km/h. With a mechanically suspended front axle and a hydro-pneumatic suspension on the rear axle this vehicle reaches a relatively high ride comfort. Rear-mounted implements directly attached to the axle will certainly result in too high dynamic wheel loads on this axle.

ZF-Axle Layout

5. The modern tractor design includes all-wheel drive and level control. The newly developed front axle APL-2000 from ZF Passau fully meets these requirements, Fig. 9.

6. The axle carrier is supported at the body by two hydro-pneumatic spring cylinders. Driving and braking forces are absorbed by the torque tube. The torque tube joins the body on one end and the axle carrier on the other end via a ball joint. The lateral guiding of the axle is made by a Panhard rod.

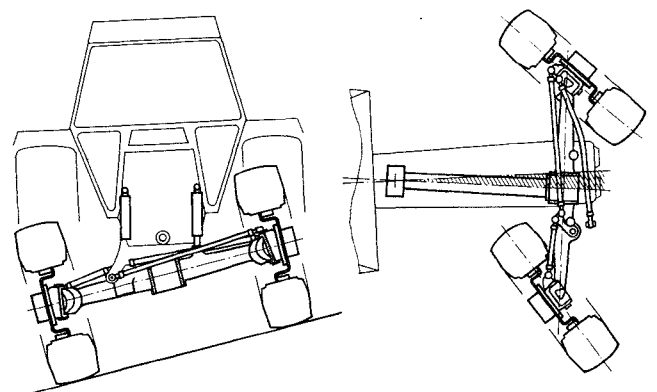

Fig. 9. Torque Tube Axle

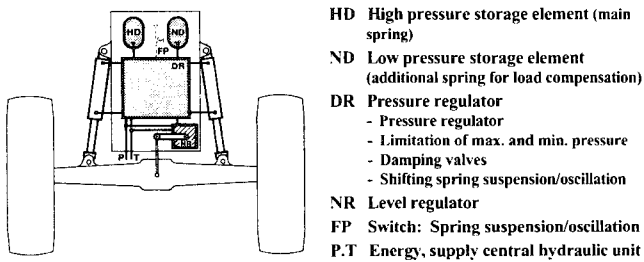

Fig. 10. Hydro-pneumatic suspension

7. The axle suspension is makes the spring engagement and disengagement possible as well as the free movement round the torque tube axle.

8. If the panhard rod is not attached to the axle carrier but to the wheel body, the axle carrier moves in lateral direction when steering. By means of the pivoted torque tube at the body, an additional steering movement of the axle is produced. Due to the lateral displacement of the axle more clearance between vehicle body and the inner tyre wall is obtained, such that a larger steering angle is possible. As a result the turning circle of the vehicle can still be reduced. Steering is alternatively made through double-acting steering cylinders or a turning lever steering.

9. The suspension is hydro-pneumatic, Fig. 10. The spring accumulators are filled with nitrogen. By means of a special regulating valve the pressure is adjusted to the static axle load. A level control valve is compensating the different vehicle loads. The axle movements are absorbed by a throttle valve. This design ensure good vibration damping characteristics even under extreme different axle loads. For special work the suspension can be locked. The axle will then behave like a standard swing axle.

Dynamic Wheel Loads and Ride Comfort

10. Fig. 11 shows the driving behaviour of a tractor with suspended front axle on an uneven roadway at the speed of 50 km/h. Even driving at high speed the wheel load variations at the front axle are considerably lower than for the standard tractor at a lower speed. The wheel load variations at the rear axle are also lower in comparison with those non suspended vehicles.

11. First of all the driver, almost sitting over the rear axle in standard tractors, profits from the suspended front axle by the reduction of the body pitching. Since the rear axle remains non-suspended, the shock loads at the driver's seat are only insignificantly affected by the suspended front axle. In this case a suspended driver's cab would compliment the effectiveness of a suspended front axle.

12. As the hydropneumatic suspension system automatically adjust to different static axle loads the advantage of a suspended front axle holds for any loading condition, Fig. 12.

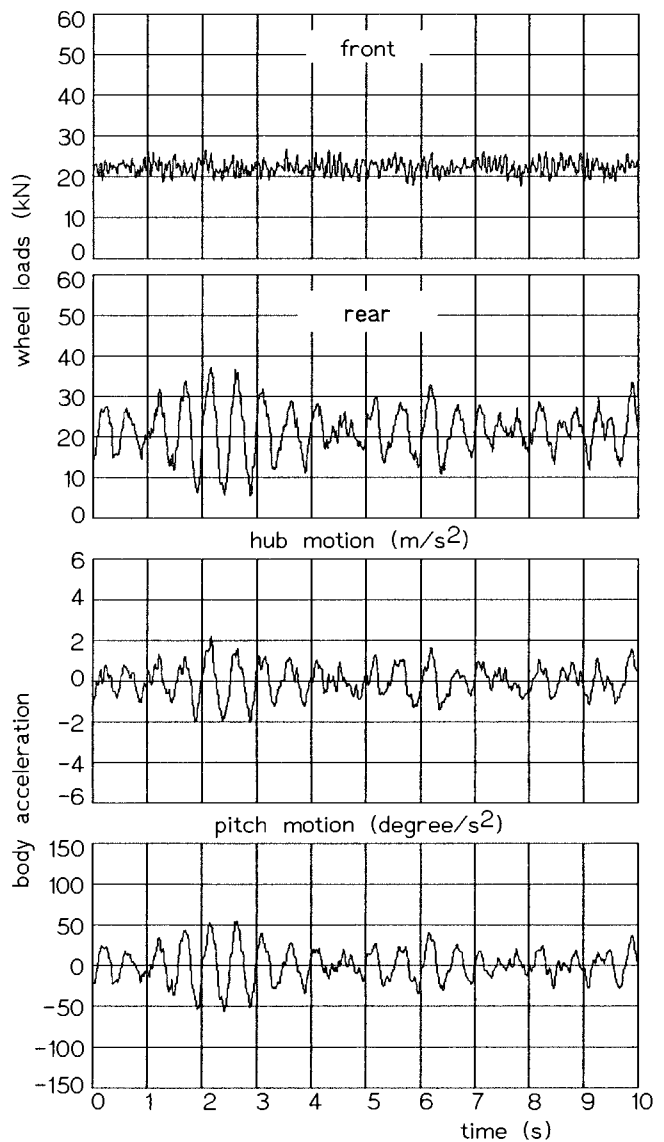

Fig. 11. Tractor with suspended front axle at high speed (50 km/h)

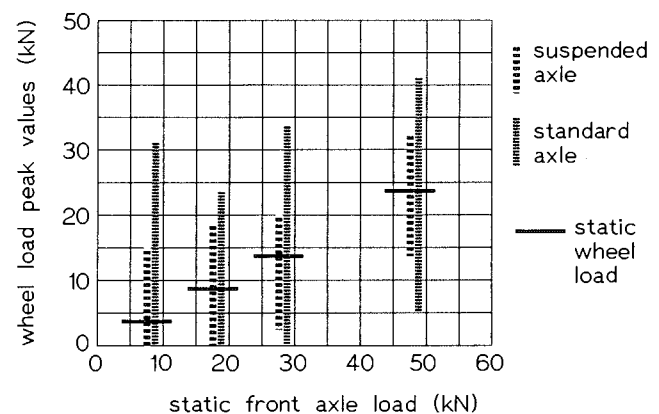

Fig. 12. Effect of suspended front axle at different loading conditions. Driving over an obstacle (25 km/h)

SIMULATION MODEL

Concept

1. The tractor body, the front axle and the four wheels are considered as rigid bodies, Fig. 13.

2. The coordinates  $x_R, y_R, z_R, \alpha_R, \beta_R, \gamma_R$  describe the location of a reference frame fixed in the tractor body with respect to the inertial frame. The movements of the tractor body are unconstrained. Rear axle and driver's cab are rigidly connected with the body. The angular speeds of the wheels are described by  $\Omega_1, \Omega_2, \Omega_3$  and  $\Omega_4$ . At point G the front axle is pivot mounted with the body. The remaining possibilities of axle movement  $\alpha_A, \beta_A, \gamma_A$  are limited by a panhard rod.

3. If the panhard rod is fixed at the wheel body, a constraint condition for the yawing movement of the axle is obtained in form of

$$\gamma_R = \gamma_R(\alpha_R, \beta_R, \delta_1) \quad (1)$$

Where  $\delta_1$  describes the rotation of the left front wheel (wheel 1) round the king pin. Steering kinematics entail another constraint condition

$$\delta_2 = \delta_2(\delta_1) \quad (2)$$

4. Thus the tractor model has  $f=9$  degrees of freedom, which are summarized in the position vector

$$y = [x_R, y_R, z_R, \alpha_R, \beta_R, \gamma_R, \alpha_A, \beta_A, \delta_1]^T \quad (3)$$

By means of generalized speeds the equations of motion can be simplified, see [2]. In this case it is adequate to apply as generalized speeds the components of

$$v_{OR,R} = [v_{Rx}, v_{Ry}, v_{Rz}]^T$$

and

$$\omega_{OR,R} = [\omega_{Rx}, \omega_{Ry}, \omega_{Rz}]^T \quad (3)$$

The vectors  $v_{OR}, \omega_{OR}$  describe the velocity and the angular velocity of the reference frame with respect to the inertial frame 0. The subscript R separated by a comma means that the components of  $v_{OR}$  and  $\omega_{OR}$  are expressed in the reference frame.

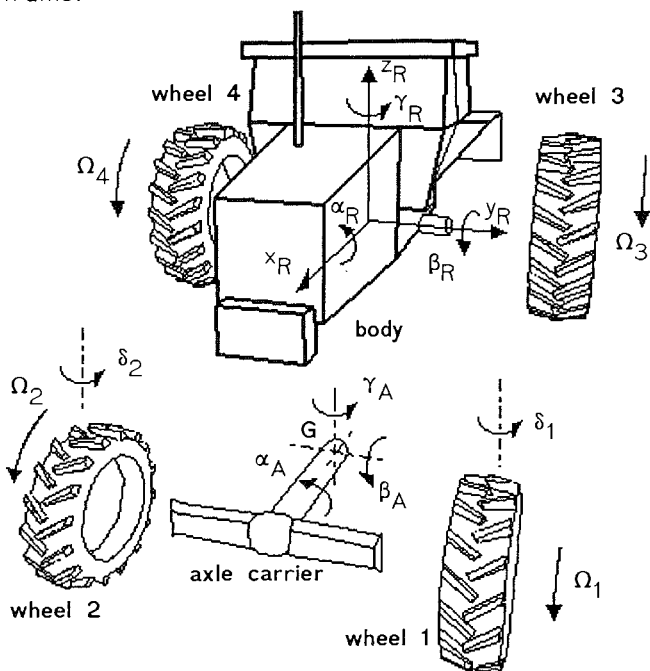

Fig. 13. Tractor model

5. By means of Jourdain's principle, see [3], the equations of motion are obtained in form of

$$K(y) * \dot{y} = z,$$

$$M(y) * \dot{z} = Q(y, z, w) \quad (4)$$

$$\dot{w} = R(y, z, w).$$

The vector of the generalized speeds is given by

$$z = [v_{Rx}, v_{Ry}, v_{Rz}, \omega_{Rx}, \omega_{Ry}, \omega_{Rz}, \alpha_A, \beta_A, \delta_1]^T \quad (5)$$

The kinematic matrix  $K(y)$  directly results from the generalized speeds chosen.

6. Due to the skilled choice of generalized speeds, the mass matrix  $M(y)$  only depends very slightly on the position vector  $y$ . Hence,  $M$  can be considered as constant for the simulation. The remaining state variables, like the angular wheel speeds  $\Omega_1, \Omega_2, \Omega_3, \Omega_4$  and the lateral tyre deflections  $y_{RE1}, y_{RE2}, y_{RE3}, y_{RE4}$  are summarized in the auxiliary vector

$$w = [\Omega_1, \Omega_2, \Omega_3, \Omega_4, y_{RE1}, y_{RE2}, y_{RE3}, y_{RE4}]^T \quad (6)$$

The lateral tyre deflections are making possible a dynamic description of the lateral forces, see [2].

7. The tractor model is described by a set of 26 non-linear first order differential equations. The nonlinearities are resulting from kinematics (steering and front axle suspension) and from the forces (tyres and hydro-pneumatic suspension).

8. During simulation random road unevennesses are generated by means of presettable spectral densities and wavinesses via interferences of band limited noise processes, see [4].

9. Numerical solution is made by means of a modified semi-implicit Euler-formula, [3]. Due to this a run-time minimized computer code is making possible the optimization of the axle suspension.

Model Quality

10. Fig. 14 and Fig. 15 show a comparison between calculations and measurements. A tractor with suspended front axle and an axle distribution as indicated above is driving on an uneven roadway with a speed of  $v = 50$  km/h.

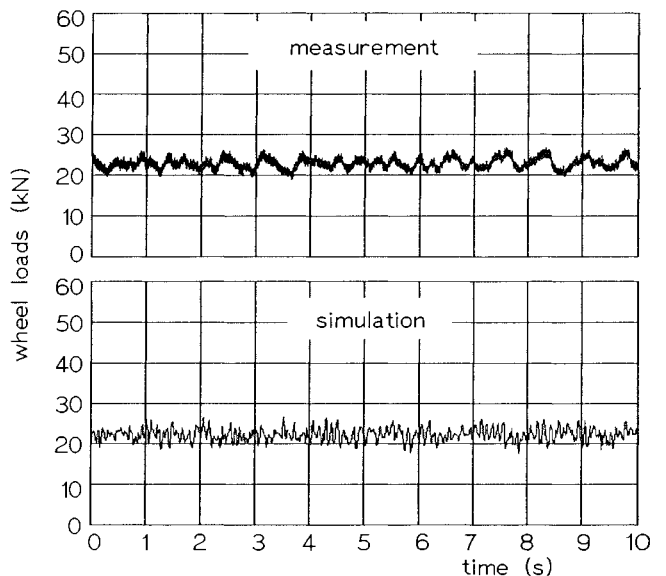

Fig. 14 Front axle wheel loads

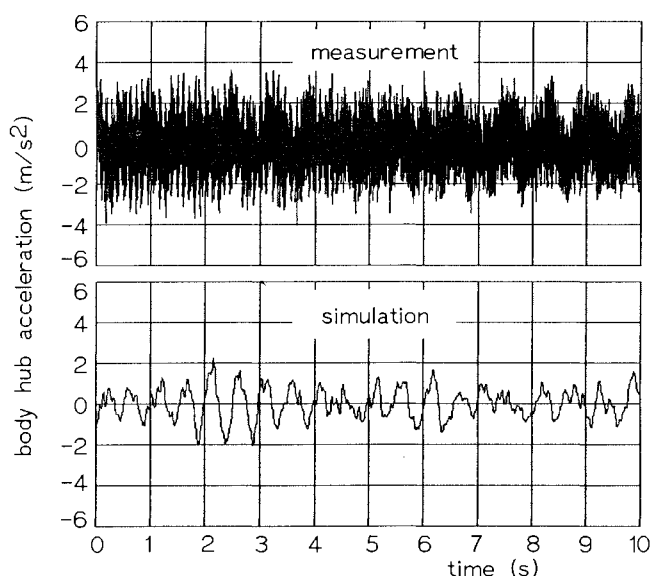

Fig. 15 Body accelerations above front axle

11. The results of simulation are in good conformity with the measurements. Both the wheel load variations as well as the body accelerations are correctly represented. The somewhat higher acceleration values of the measurement are supposed to be due to friction in the axle suspension.

12. With a tractor model verified at a prototype now the front axle suspension can be adapted to each tractor version without any essential work to be done.

## CONCLUSION

1. This paper shows that by use of a suspended front axle the ride comfort and the ride safety of heavy agricultural tractors are considerably improved. Even at high driving speeds an improved ride safety and almost the same ride comfort are obtained as with non-suspended tractors at a lower driving speed by means of the perfectly adjusted hydro-pneumatic front axle suspension. An increase of the driving speed, however results in a higher economy, since times to be spent only for transport work are reduced.

2. The front axle developed by ZF Passau offers a number of advantages. By means of the simulation program ATRACTION (Agricultural Tractor Simulation) The front axle is perfectly adaptable to all vehicles.

## REFERENCES

1. Ehrlinger, F.; Carlson, R. Improved Economy and Mobility in FWD Axles. SAE Technical Paper Series 821064, 1982.
2. RILL G. Steady State Cornering on Uneven Roadways. SAE Technical Paper Series No 860575, 1986.
3. RILL G. Vehicle Dynamics in Real-Time Simulation. In: The Dynamics of Vehicles on Roads and on Tracks. Ed.: Apetaur, M., Lisse: Swets-Zeitlinger 1988.
4. RILL G. Demands on Vehicle Modeling. In: The Dynamics of Vehicles on Roads and on Tracks. Ed.: Anderson, R.J., Lisse: Swets-Zeitlinger 1990.

5. Paul, M.; Wilks, E. Driven Front Axles for Agricultural Tractors. ASAE (American Society of Agricultural Engineers) Distinguished Lecture Series, Tractor Design No. 14, 1989.

6. Wimbeck, M. Vergleich zwischen Messung und Fahr-simulationsrechnung am Beispiel eines vorderachsgefederten Schleppers. Diplomarbeit an der FH Regensburg, Regensburg 1991.