

# AN ALTERNATIVE MEASURE FOR EVALUATING THE DYNAMIC PERFORMANCE OF HEAVY VEHICLES

**Séamus P.S. Parker**

Forest Engineering Research Institute of Canada (FERIC)

## ABSTRACT

Ideally a performance measure should accurately characterize the desired attribute and be easily measured experimentally. The most common performance measures for characterizing the dynamic performance of heavy vehicles are load transfer ratio (LTR) and rearward amplification (RA). LTR is often considered the ultimate dynamic performance measure since it directly measures the vehicle's tendency to rollover. However, this measure is extremely difficult to measure experimentally. RA has been widely used by the heavy vehicle researchers since it is relatively easy to measure experimentally. However this measure does not account for roll coupling and results in inconsistent dynamic performance levels between different vehicle types. Further development and rationalization of heavy vehicle performance measures in Australia and New Zealand has resulted in an improved method of calculating RA which accounts for roll coupling. An alternative performance measure for evaluating dynamic performance is presented in this paper, which builds on the concepts introduced by the Australia/New Zealand RA performance measure. This performance measure is termed rollover capacity ratio (RCR), which expresses the resultant lateral acceleration of a roll-coupled unit as a proportion of its static rollover threshold. Computer simulations were performed for three different heavy vehicle configurations (tractor/semi-trailer, B-train, and truck/full trailer) and the performance measures for RCR, LTR and SRT computed. The proposed performance measure is evaluated in terms of its ability to effectively measure a configuration's dynamic performance relative to LTR, and minimum performance criteria for this measure are proposed.

## INTRODUCTION

Since the 1980s, there has been extensive research in the development and application of performance measures to aid the regulation of heavy vehicle weights and dimensions. Ideally a performance measure should accurately characterize the desired attribute and be easily measured experimentally. The most common performance measures for characterizing dynamic performance are load transfer ratio (LTR) and rearward amplification (RA).

LTR is the difference in wheel loads from one side of the vehicle to the other divided by the total load of the vehicle (El-Gindy, 1992). LTR is calculated separately for each individual roll coupled unit. In all cases the front steering axle is excluded from the calculation due to its high roll compliance. LTR is often considered the ultimate dynamic performance measure since it directly measures the vehicle's tendency to rollover. However, this measure is extremely difficult to measure experimentally, requiring instrumentation to measure separate wheel loads. Therefore the use of this performance measure is effectively limited to computer simulation modeling.

The classical definition of RA is the ratio of the peak lateral acceleration at the centre of gravity of the rearmost trailer relative to the peak input lateral acceleration at the leading unit's centre of gravity (El-Gindy, 1992). An alternative means of evaluating RA uses the steering axle as the input lateral acceleration, but this is not universally applied. This performance measure has been widely used by heavy vehicle researchers since it is relatively easy to measure experimentally. However, this measure does not account for roll coupling and results in inconsistent dynamic performance levels between different vehicle types. For example a roll-coupled vehicle could achieve a high RA while remaining stable, whereas a non roll-coupled unit could become very unstable at the same RA.

In recent years, further development and rationalization of heavy vehicle performance measures has taken place in Australia and New Zealand coordinated by the National Road Transport Commission (NRTC) (Edgar, Prem, Calvert, 2002). As a result, a revised method of calculating RA has been adopted to replace LTR. This method accounts for roll coupling, and links acceptable performance levels to the rollover threshold of the roll coupled unit. RA is expressed as the maximum resultant lateral acceleration for the rearmost roll coupled unit relative to the maximum lateral acceleration at the steering axle (Prem, McLean, Edgar, 2003). The classical method of evaluating RA calculates the RA of the rearmost sprung mass only, not the roll-coupled unit as a whole, thereby resulting in higher RA values. The NRTC method of calculating RA is a significant advancement in evaluating the dynamic performance of heavy vehicle combinations, particularly since it is a measure that can be experimentally determined.

This paper presents an alternative measure for evaluating dynamic performance which builds on the concepts introduced by the NRTC RA performance measure. This performance measure will henceforth in this paper be referred to as Rollover Capacity Ratio (RCR) and is defined as follows:

$$RCR_{rcu} = \frac{|AY_{rcu}|_{\max}}{SRT_{rcu}} \quad (1)$$

where:

$AY_{rcu}$  = resultant lateral acceleration of each roll coupled unit (rcu) (g)

$SRT_{rcu}$  = static rollover threshold of each roll coupled unit (g)

$AY_{rcu}$  is calculated similarly to the method used in the NRTC revised RA measure, namely:

$$AY_{rcu} = \frac{\sum_{n=1}^N m_n h_n AY_n}{\sum_{n=1}^N m_n h_n} \quad (2)$$

where:

$m_{1..n}$  = mass of each sprung mass within each roll coupled unit (kg)

$h_{1..n}$  = height of each sprung mass CG within roll coupled unit (m)

$AY_{1..n}$  = lateral acceleration of each sprung mass CG within roll coupled unit(g)

One difference between this proposed performance measure and the NRTC RA performance measure is that the tractor or truck mass and lateral acceleration is included in the calculation of  $AY_{rcu}$  in the case of the proposed performance measure. RCR is calculated for each roll-coupled unit within the vehicle and the maximum value of all roll-coupled units is reported.

## Objective

The objective of this paper is to illustrate the application of the proposed performance measure for sample heavy vehicle configurations and to assess the measure's ability to predict dynamic performance.

## METHODOLOGY

Computer simulations were performed using the University of Michigan Transportation Research Institute's (UMTRI) yaw/roll model for the following heavy vehicle configurations:

- Tractor/semi trailer (figure 1)
- B-train (figure 2)
- Truck/ full trailer (figure 3)

The weights and dimensions used in the simulations are illustrated in figures 1, 2 and 3 and represent current western Canadian regulations and typical equipment specifications for logging trucks at a load density of 460 kg/m<sup>3</sup>.

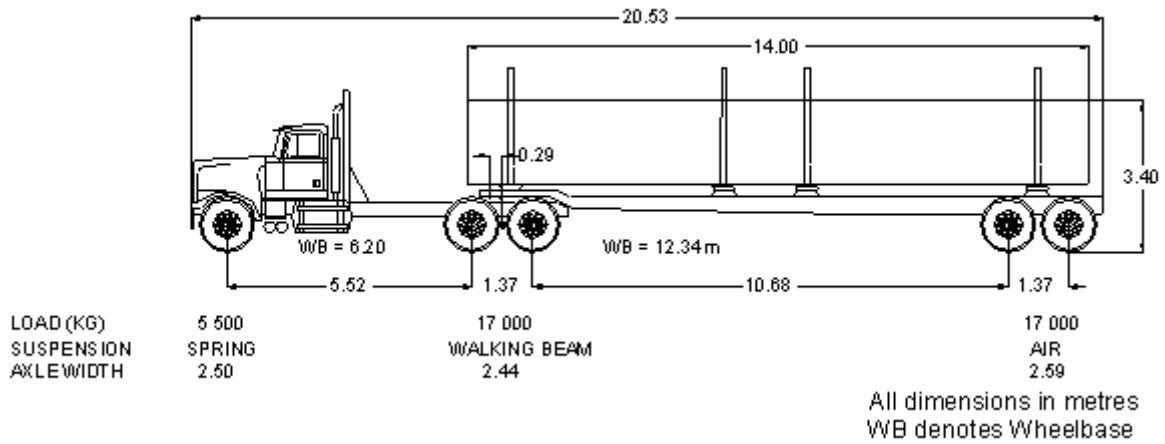

Figure 1. Weights and dimensions of tractor/semi-trailer.

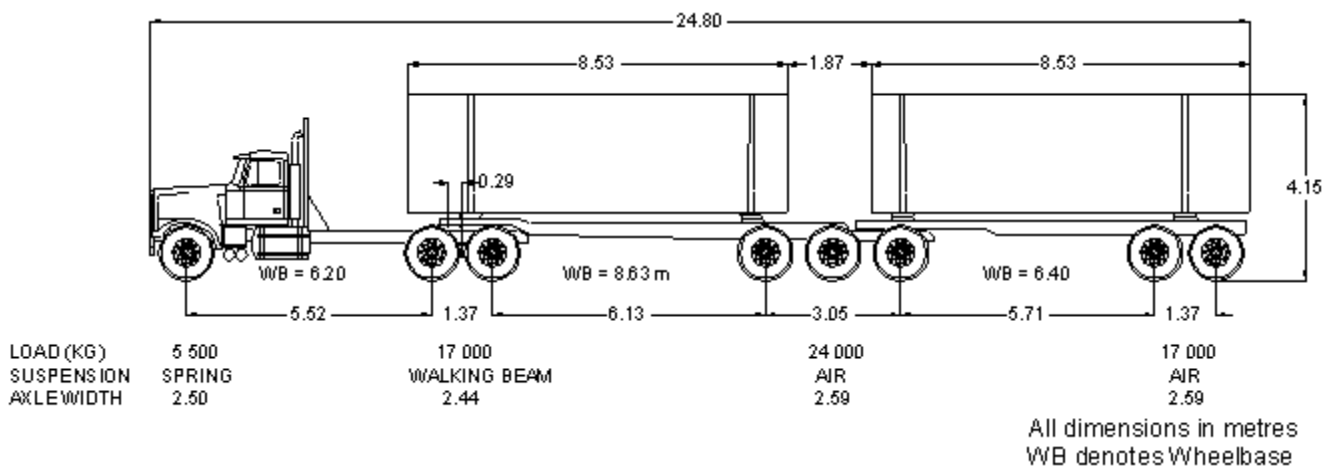

Figure 2. Weights and dimensions of B-train.

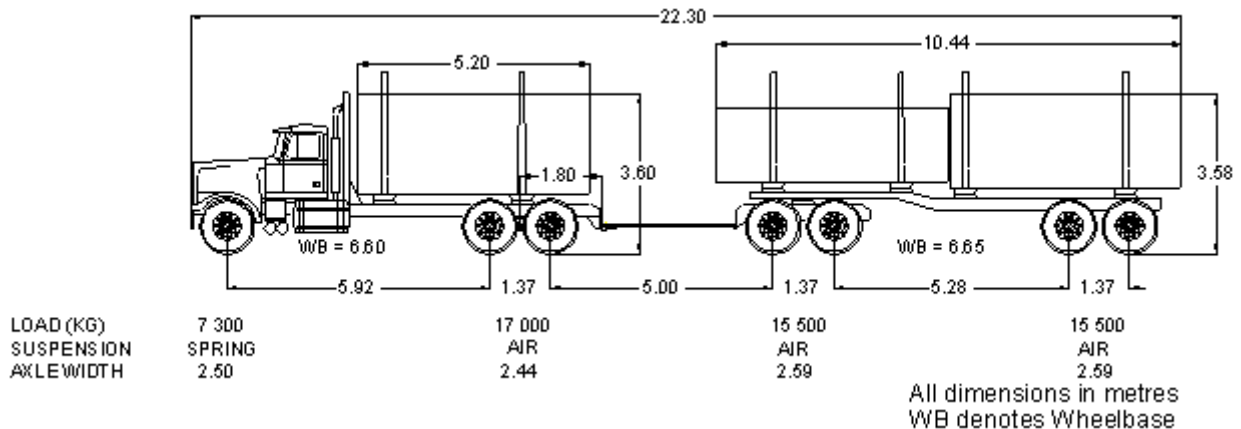

Figure 3. Weights and dimensions of truck/full trailer.

The simulations were conducted for a high-speed path-change manoeuvre at 88 km/h, yielding a lateral acceleration amplitude at the steering axle of 0.15 g within a time period of 2.5 seconds (i.e. SAE J2179 test parameters). From the simulation data, both RCR and LTR were calculated at each time step in the manoeuvre and for each roll-coupled unit. For both the tractor/semi-trailer and the B-train, the entire configuration is considered a roll-coupled unit. The truck/full trailer is considered two roll-coupled units with the truck being one unit and the combined dolly/trailer mass being the second unit. In order to calculate RCR, the static rollover threshold (SRT) of each roll coupled is required. SRT is determined through an

additional simulation run of a ramp steer manoeuvre, whereby the steering wheel angle is increased at a rate of 2 degrees/sec until rollover occurs.

## RESULTS AND DISCUSSION

The maximum LTR and RCR values are summarized in Table 1 for the three sample configurations. In addition the SRT for each roll-coupled unit is also presented. The time histories for each configuration are illustrated in figures 4, 5 and 6. RCR correlated very closely with LTR for the tractor/semi-trailer and B-train, with close to identical time history and peak values. The full trailer roll coupled unit of the truck/full trailer exhibited a maximum RCR approximately 4% less than the maximum LTR, while the truck's maximum RCR was approximately 14% below the maximum LTR. In addition, the truck's RCR and LTR were slightly out of phase with each other. The large differences between RCR and LTR, as well as the phase lag for the truck are primarily a result of not including the steering axle load in the calculation of LTR, and the high proportion of load carried by the steering axle for this unit. For the tractor/semi-trailer and B-train, the tractor's contribution to the resultant lateral acceleration of the roll-coupled unit is relatively minor, and hence the contribution of the steering axle load does not have a significant impact on the calculation of RCR. It can be argued in the case of the truck that not including the steering axle load in the calculation of LTR underestimates the dynamic stability of the truck, as the heavier steering axle suspension in this case provides more roll resistance than with light tractor steering suspensions. Nevertheless a modified procedure should be applied in the calculation of the RCR of trucks to improve its correlation with LTR. Possible solutions include placing the accelerometer more rearward or applying an adjustment factor in the calculation of RCR for trucks (e.g. 1.15).

Table 1. Summary of performance measures for sample configurations.

Configuration	Performance Measure		
	SRT (g)	LTR	RCR
Tractor/semi-trailer	0.381	0.358	0.363
Super B-train	0.315	0.480	0.476
Truck/full trailer			
Truck	0.342	0.640	0.549
Trailer	0.420	0.677	0.652

Despite the close correlation between LTR and RCR, they are different performance measures and should not be considered equivalent. RCR is intended to be a simplified measure that indicates the relative dynamic stability of a configuration in terms of its SRT. The calculation of RCR does not account for the roll moment created by the product of vertical force at the sprung mass and the lateral displacement of the sprung mass due to body roll. In cases where body roll is minimal, RCR will be similar in magnitude to LTR, but as body roll increases LTR will increase relative to RCR. Also the contributions of the unsprung masses to the net lateral acceleration are unaccounted for. Despite these neglected factors, the three sample configurations illustrate that RCR gives a relatively good indication of dynamic stability yielding similar results to LTR in most cases. RCR provides an improved means relative to RA of comparing dynamic performance between different configuration types, which can be measured in the field. In order to measure RCR, roll compensated lateral accelerometers are required at each sprung mass centre of gravity (CG) location. In addition SRT, sprung mass weights and CG heights must be measured. The instrumentation required to measure lateral accelerations and roll angles are the same as required to measure RA, but a greater number of sensors are needed to quantify RCR depending on the configuration. However the instrumentation requirements are much less than what would be required to accurately measure LTR.

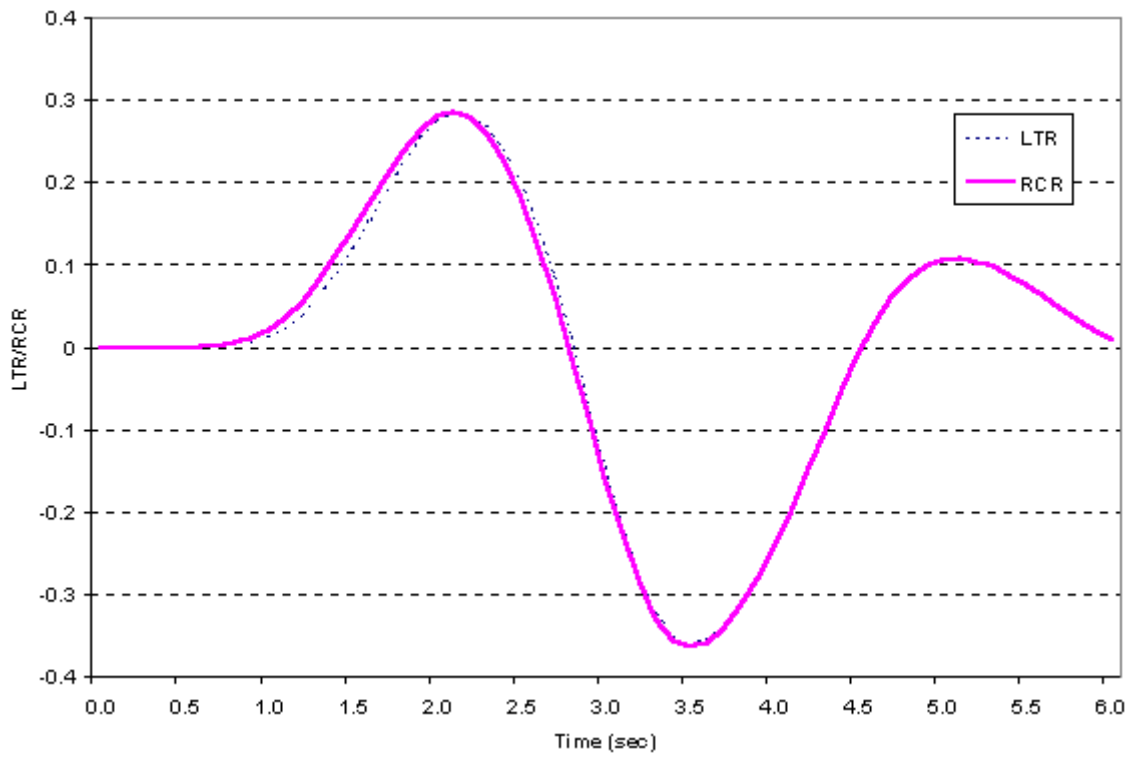

Figure 4. Tractor/semi-trailer - time history plot of LTR and RCR.

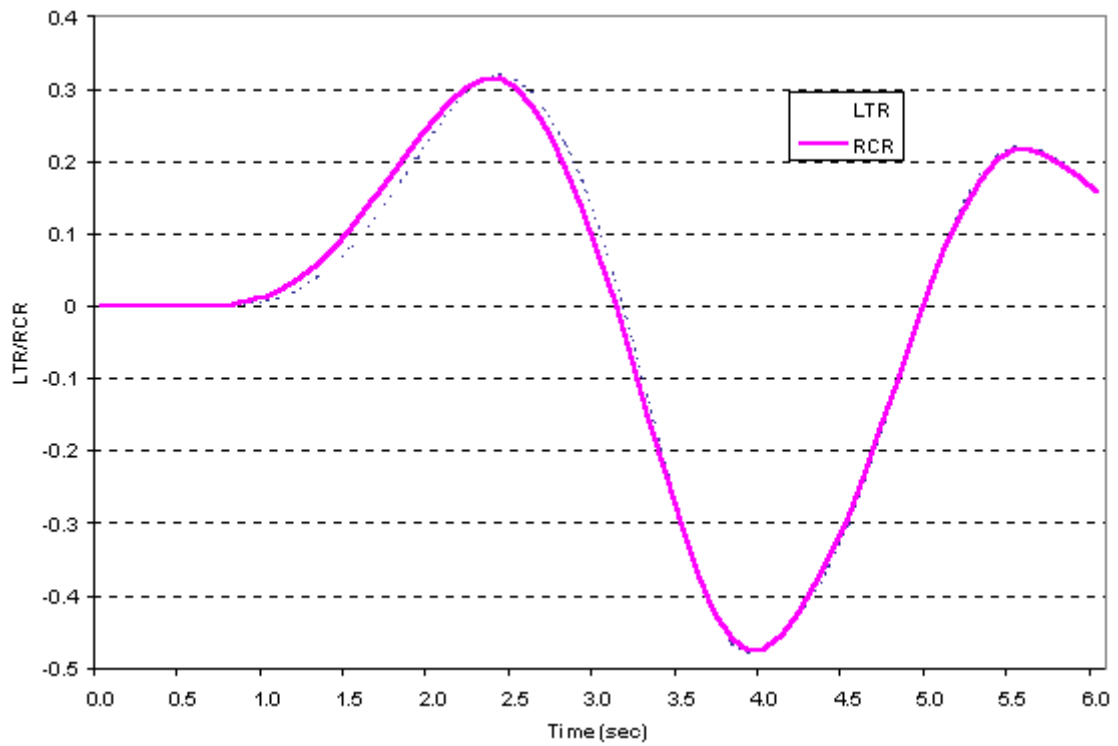

Figure 5. B-train - time history plot of LTR and RCR.

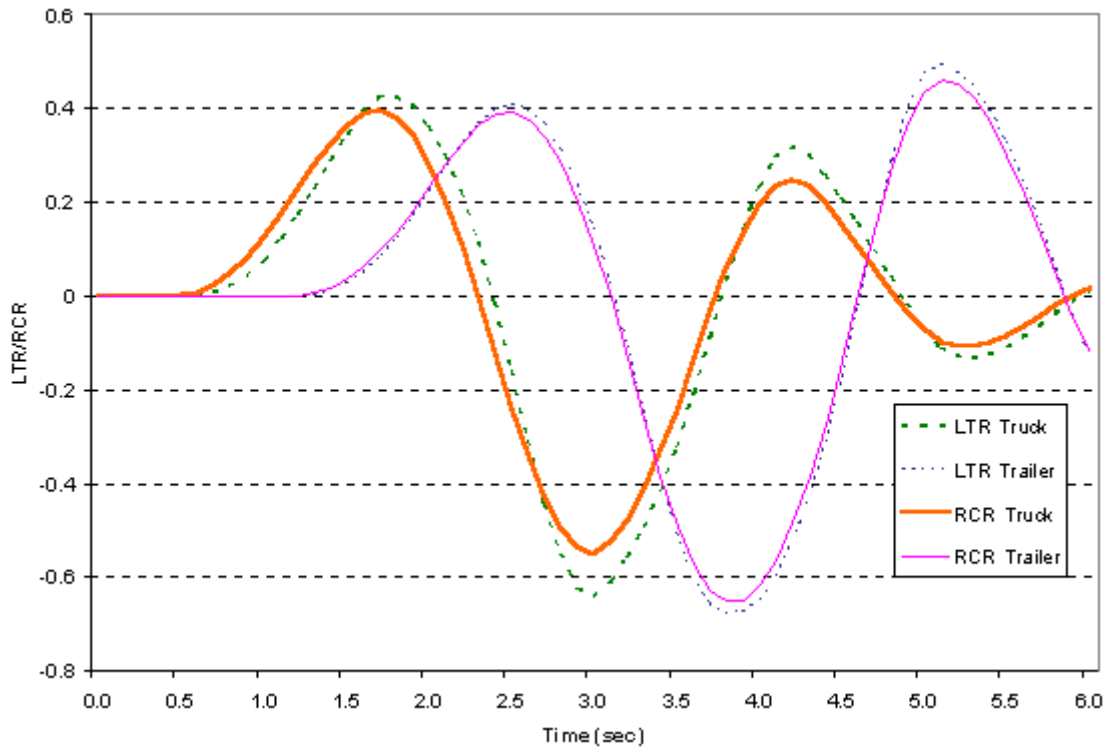

Figure 6. Truck/full trailer - time history plot of LTR and RCR.

It is proposed that the performance standard for RCR be a compromise of existing performance standards for RA, LTR, and SRT. For example a truck/full trailer achieves the performance standard of 0.35 g and 2.0 for SRT and RA respectively in an evasive manoeuvre of 0.15 g input acceleration at the steering axle. In this case, the resulting lateral acceleration at the full trailer (rear most roll coupled unit) is 0.30 g (i.e. 2.0 multiplied by 0.15), yielding a RCR of 0.86 (i.e. 0.30 g divided by 0.35 g). This level is significantly higher than the LTR performance standard of 0.60. A suggested compromise of these two levels is a maximum allowable RCR of 0.70.

At this proposed performance level, the maximum RA is considerably less than the current limit of 2.0, when the full trailer meets the minimum SRT performance level of 0.35 g in a standard evasive manoeuvre:

$$RA = \frac{(0.70)(0.35g)}{(0.15g)} = 1.63 \quad \text{i.e. } RA = \frac{(RCR)(SRT)}{(input\_acceleration)}$$

In order for the current maximum RA of 2.0 to be achieved the full trailer would require a higher SRT level:

$$SRT = \frac{(2.0)(0.15g)}{(0.70)} = 0.43g \quad \text{i.e. } SRT = \frac{(RA)(input\_acceleration)}{(RCR)}$$

At a RCR of 0.70, the SRT of the roll-coupled unit is 43% higher than the resultant lateral acceleration (i.e.  $SRT/AY=1/0.70=1.43$ ), thereby providing an adequate safety margin against rollover.

At this point in time, RCR is a theoretical performance measure that has only been used with computer simulation. Therefore field tests are required to further evaluate the practical effectiveness of RCR with as many different configurations as possible. Further development of this performance measure to include the influence of body roll and the roll moment created by the sprung mass vertical force component would improve its value allowing it to more closely approximate LTR.

## **CONCLUSIONS**

- RCR correlated very closely with LTR for the tractor/semi-trailer and Super B-train, with close to identical time history and peak values. RCR for the full trailer unit of the truck/full trailer also correlated closely to LTR.
- RCR for the truck unit of the truck/full trailer was approximately 14% lower than its LTR value. This difference is primarily due to not including the steering axle load in the calculation of LTR, and the high proportion of load carried by the steering axle for this unit. An alternative procedure should be applied to calculate the RCR of trucks to better represent the dynamic performance of these units, such as an adjustment factor.
- RCR provides a simple and effective means of evaluating dynamic performance that can be measured in the field. In order to measure RCR, roll compensated lateral accelerometers are required at each sprung mass. In addition SRT, sprung mass weights and CG positions must be measured or estimated.
- The proposed performance for RCR is a maximum level of 0.70, which provides a safety factor of 1.43.

## **RECOMMENDATIONS**

- Conduct field tests to evaluate the practical effectiveness of RCR with as many different configurations as possible.
- Further develop the RCR performance measure to include the influence of body roll and the roll moment created by the sprung mass vertical force component.

## **REFERENCES**

1. El-Gindy, M, 1992. The use of heavy vehicle performance measures for design and regulation. ASME Winter Annual Meeting, Anaheim, CA.
2. Edgar, J, Prem, H, Calvert, F, 2002. Applying performance standards to the Australian heavy vehicle fleet. Proc. 7<sup>th</sup> International Symposium Heavy Vehicle Weights and Dimensions.
3. Prem, H, McLean, J, Edgar, J, 2003. PBS safety standards for heavy vehicles. National Road Transport Commission Discussion Paper.